



ADDENDUM NO. 2  
Appoquinimink School District  
Silver Lake Elementary School  
Additions and Renovations – Bid Package 'A'  
Page 1

January 6, 2019

**The bid due date and time remains unchanged.**

**Bids will be received until 3:00 p.m. on Tuesday, January 14, 2020. The location for receipt of bids has changed to Room 138 of the Appoquinimink School District, Marion Profitt Training Center, 118 South Sixth Street, Odessa, Delaware 19730**

NOTICE: Attach this addendum to the project manual for this project. It modifies and becomes a part of the contract documents. Work or materials not specifically mentioned herein are to be described in the main body of the specifications and as shown on the drawings. Bidders shall acknowledge receipt of this addendum on the space provided on the Bid Form. Failure to do so may subject the bidder to disqualification.

Whenever this Addendum modifies a portion of the Project Manual added information is shown as **Bold** and deleted information is shown as ~~strike through~~.

The contract documents for the above referenced project, dated December 6, 2019 are amended as follows:

QUESTIONS AND ANSWERS:

1. See response to RFI's 1, 2, 3, 4, 6, 7, 8, 9, 10, 11, 12, 13, 14, 15, 16, 17, 18, 19, 20, 23, 24, 25, 26, 27, 29, 31, 32, 33, 34, 35, 42, 43, 44, 48, 49, 50, 51, 52, 62, 63, 64.

MODIFICATIONS TO SPECIFICATIONS:

1. Section 004100 – Bid Forms
  - a. Updated bid forms are being provided for the following contracts:
    - i. Contract A-07 – Roofing
    - ii. Contract A-21 – Electrical
    - iii. Contract A-25 – Telephone System
2. Section 011100 – Summary of Work
  - a. This section is being reissued as part of this addendum.





3. Section 012300 – Alternates
  - a. Make the following pen and ink change. Add the following to Paragraph C:  
**Alternate No. 12: Lightning Protection System**
    - a. **Base Bid: No work is required.**
    - b. **Alternate: Provide lightning protection system for the entire building.**
4. Section 013216 – Construction Schedule
  - a. Insert the Construction Schedule annotated “Addendum #2”, dated 06 January 2020.
5. Section 016200 – Material and Equipment
  1. Revised paragraph 6.C.2 to read as follows:
    - a. Requests for substitutions shall be made in writing to the Architect at least **seven (7)** ~~ten~~ days prior to the date of the Bid Opening. Such requests shall include a complete description of the proposed substitution, drawings, performance and test data, explanation of required installation modifications due the substitution, and any other information necessary for an evaluation. The burden of proof of the merit of the proposed substitution is upon the proposer. The Architect’s decision of approval or disapproval shall be final. The Architect is to notify Owner prior to any approvals.

**MODIFICATIONS TO DRAWINGS:**

1. Structural Drawings – The following sheets have been replaced in their entirety:
  - a. S11.D; S11.E; S513; S515; updates the deck composition at the gym bldg.
2. Interior Drawings – The following sheets have been replaced in their entirety:
  - a. A90.A – FINISH PLAN AREA ‘A’
    - i. CORRIDOR (119) - Flooring changed from VT-1,2,3 to VT-1
    - ii. BREAKROOM (123) – Flooring pattern added
  - b. A90.B – FINISH PLAN AREA ‘B’
    - i. COTS (611) and TREATMENT ROOM (614) Flooring pattern identified
    - ii. TECH / STEM (134 & 135) Flooring pattern identified
    - iii. MEDIA CENTER (132) Carpet tile types identified with associated hatch patterns. Finish tag changed from LVT-3 to LVT-5
    - iv. RESOURCE (208, 217) and FACULTY (209, 218) Flooring patterns identified
  - c. A90.C – FINISH PLAN AREA ‘C’
    - i. RESOURCE (307), FACULTY (306), ESL (316), FACULTY (326), and RESOURCE (325) Flooring patterns identified
    - ii. STORAGE (332) Floor finish changed to VT-1
  - d. A90.D – FINISH PLAN AREA ‘D’
    - i. GYMNASIUM (502) and FITNESS (503) Floor finish changed to RGF-1 as ‘Base Bid’
    - ii. AWD-1 Changed to ‘NOT USED’ in the Finish Materials Schedule





- iii. RGF-1 and SS-3 Added to the Finish Materials Schedule
  - e. A91.A – CASEWORK PLANS AND ELEVATIONS
    - i. Casework height changes in drawings 5, 7, and 13
  - f. A91.B – CASEWORK PLANS AND ELEVATIONS
    - i. Casework height changes in drawings 2 and 15
  - g. A91.F – CASEWORK SECTIONS
    - i. Section 8 added for details on plastic laminate countertops at sinks
    - ii. Section 9 added for details relating to cubbies and overhead cabinets
    - iii. Section 2 changes in dimensions for the mounting height of the overhead cabinets.
3. Kitchen Drawings– The following sheets have been replaced in their entirety:
- a. K-104; K-502, Per the District’s instruction, the 480V in the Utility Raceway was removed.
4. Architectural Drawings – The following sheets have been replaced in their entirety:
- a. Sheet A10.B; modifies wall type and location at corridors in order to enclose columns.
  - b. Sheet A12.1; additional wall types
  - c. Sheet A12.4; wall plan details
  - d. Sheet A50.9; adjustment on wall dimensions and relation with folding partition
5. Sketches A-SKE-1; A.SKE-2 are being issued in response to RFI#029, windows apron details.

End of Addendum No. 2





APPOQUINIMINK SCHOOL DISTRICT  
WHITEHALL ELEMENTARY SCHOOL  
CONSTRUCTION SCHEDULE



Appoquinimink School District  
THE WORLD IS OUR CAMPUS

ID	Task Name	Duration	Start	Finish	Jan	Feb	Mar	Apr	May	Jun	Jul
1	<b>SILVER LAKE ELEMENTARY SCHOOL- ADDITIONS &amp; RENOVATIONS</b>	<b>467 days</b>	<b>Thu 11/14/19</b>	<b>Mon 8/30/21</b>	[Gantt bar from Jan to Jul]						
2	<b>SLES - BIDDING &amp; AWARD ACTIVITIES</b>	<b>74 days</b>	<b>Thu 11/14/19</b>	<b>Tue 2/25/20</b>	[Gantt bar from Jan to Feb]						
3	A/E revises CD's from DFM/DOE Review & Plan Check	15 days	Thu 11/14/19	Wed 12/4/19	[Gantt bar from Jan to Feb]						
4	EDIS Rec/Prepares Bid Pack A Documents for Bidding	9 days	Mon 11/25/19	Thu 12/5/19	[Gantt bar from Jan to Feb]						
5	Submit to Government Support Services (GSS) for Review	0 days	Thu 12/5/19	Thu 12/5/19	[Gantt bar from Jan to Feb]						
6	GSS Posts to MYMARKETPLACE.COM	6 days	Fri 12/6/19	Fri 12/13/19	[Gantt bar from Jan to Feb]						
7	1st Bid Advertisement	0 days	Thu 12/12/19	Thu 12/12/19	[Gantt bar from Jan to Feb]						
8	2nd Bid Advertisement	1 day	Mon 12/16/19	Mon 12/16/19	[Gantt bar from Jan to Feb]						
9	Pre-Bid Meeting and Site Visit at SLES (4:00 PM)	1 day	Thu 12/19/19	Thu 12/19/19	[Gantt bar from Jan to Feb]						
10	Bidding Period	17 days	Fri 12/20/19	Mon 1/13/20	[Gantt bar from Jan to Feb]						
11	Bid Opening at MPTC (3:00 PM)	1 day	Tue 1/14/20	Tue 1/14/20	[Gantt bar from Jan to Feb]						
12	Bid Review & Recommendation to Owner	15 days	Wed 1/15/20	Tue 2/4/20	[Gantt bar from Jan to Feb]						
13	Contracts Presented at School Board Mtg	1 day	Tue 2/11/20	Tue 2/11/20	[Gantt bar from Jan to Feb]						
14	Letters of Intent Issued and Contracts Awarded	10 days	Wed 2/12/20	Tue 2/25/20	[Gantt bar from Jan to Feb]						
15	<b>SLES - CONSTRUCTION ACTIVITIES</b>	<b>378 days</b>	<b>Wed 2/19/20</b>	<b>Fri 7/30/21</b>	[Gantt bar from Feb to Jul]						
16	<b>OWNER ACTIVITIES</b>	<b>12 days</b>	<b>Thu 6/11/20</b>	<b>Fri 6/26/20</b>	[Gantt bar from Jun to Jul]						
17	Last day for Students	1 day	Thu 6/11/20	Thu 6/11/20	[Gantt bar from Jun to Jul]						
18	Last day for Teachers	1 day	Tue 6/16/20	Tue 6/16/20	[Gantt bar from Jun to Jul]						
19	ASD Prepares for Moving	3 days	Wed 6/17/20	Fri 6/19/20	[Gantt bar from Jun to Jul]						
20	Movers Empty Building	5 days	Mon 6/22/20	Fri 6/26/20	[Gantt bar from Jun to Jul]						
21	<b>CRITICAL SUBMITTALS</b>	<b>45 days</b>	<b>Wed 2/19/20</b>	<b>Tue 4/21/20</b>	[Gantt bar from Feb to Apr]						
37	<b>MATERIAL LEAD TIMES</b>	<b>85 days</b>	<b>Wed 3/18/20</b>	<b>Tue 7/14/20</b>	[Gantt bar from Mar to Jul]						
53	<b>PRELIMINARY SITEWORK</b>	<b>175 days</b>	<b>Wed 2/26/20</b>	<b>Tue 10/27/20</b>	[Gantt bar from Feb to Oct]						
54	Town of Middletown Preconstruction Meeting	1 day	Wed 2/26/20	Wed 2/26/20	[Gantt bar from Feb to Oct]						
55	DNREC Preconstruction Meeting	1 day	Thu 2/27/20	Thu 2/27/20	[Gantt bar from Feb to Oct]						
56	Mobilize	5 days	Wed 4/1/20	Tue 4/7/20	[Gantt bar from Feb to Oct]						
57	Install (SECP) Sediment & Erosion Control Measures	10 days	Wed 4/8/20	Tue 4/21/20	[Gantt bar from Feb to Oct]						
58	Install Temporary Safety Measures (Walkway, Signage, etc.)	5 days	Wed 4/22/20	Tue 4/28/20	[Gantt bar from Feb to Oct]						
59	Initial Site Demolition	5 days	Wed 4/29/20	Tue 5/5/20	[Gantt bar from Feb to Oct]						
60	Install Sanitary Sewers	10 days	Wed 5/6/20	Tue 5/19/20	[Gantt bar from Feb to Oct]						
61	Install Storm Sewers	5 days	Wed 5/20/20	Tue 5/26/20	[Gantt bar from Feb to Oct]						
62	Install Grease Trap	3 days	Fri 10/23/20	Tue 10/27/20	[Gantt bar from Feb to Oct]						
63	<b>BUILDING FOUNDATIONS &amp; SLABS</b>	<b>73 days</b>	<b>Wed 5/27/20</b>	<b>Fri 9/4/20</b>	[Gantt bar from May to Sep]						
64	<b>Gymnasium Addition</b>	<b>46 days</b>	<b>Wed 5/27/20</b>	<b>Wed 7/29/20</b>	[Gantt bar from May to Sep]						
74	<b>Classroom Addition</b>	<b>61 days</b>	<b>Fri 6/12/20</b>	<b>Fri 9/4/20</b>	[Gantt bar from May to Sep]						
84	<b>Common Areas Additions</b>	<b>20 days</b>	<b>Mon 6/29/20</b>	<b>Fri 7/24/20</b>	[Gantt bar from May to Sep]						
94	<b>Existing Building Renovations</b>	<b>38 days</b>	<b>Mon 6/29/20</b>	<b>Wed 8/19/20</b>	[Gantt bar from May to Sep]						
104	<b>BUILDING STRUCTURE &amp; ENVELOPE</b>	<b>91 days</b>	<b>Mon 7/27/20</b>	<b>Mon 11/30/20</b>	[Gantt bar from Jun to Nov]						
105	<b>Gymnasium Addition</b>	<b>67 days</b>	<b>Thu 7/30/20</b>	<b>Fri 10/30/20</b>	[Gantt bar from Jun to Nov]						

Appoquinimink School District Silver Lake Elementary School Date: 6 Jan 20, Addendum No. 2

s Milestone Project Summary Start-only Progress   
 Split Summary Manual Summary Finish-only Deadline



**APPOQUINIMINK SCHOOL DISTRICT  
WHITEHALL ELEMENTARY SCHOOL  
CONSTRUCTION SCHEDULE**



**Appoquinimink School District**  
THE WORLD IS OUR CAMPUS

ID	Task Name	Duration	Start	Finish	2020							
					Jan	Feb	Mar	Apr	May	Jun	Jul	
117	Classroom Addition	61 days	Mon 9/7/20	Mon 11/30/20								
128	Common Areas Additions	49 days	Mon 7/27/20	Thu 10/1/20								7/27/20
139	Existing Building Renovations	69 days	Mon 8/10/20	Thu 11/12/20								8/10/20
153	BUILDING INTERIOR ROUGHINS	194 days	Thu 8/20/20	Tue 5/18/21								
154	Gymnasium Addition	55 days	Wed 9/23/20	Tue 12/8/20								
162	Classroom Addition	60 days	Mon 11/16/20	Fri 2/5/21								
171	Existing Building Renovations	136 days	Thu 8/20/20	Thu 2/25/21								
181	Mechanical & Electrical Component Installations	45 days	Thu 8/27/20	Wed 10/28/20								
187	Mechanical & Electrical Equipment Startups	74 days	Thu 12/24/20	Tue 4/6/21								
195	Testing, Adjusting, & Balancing	30 days	Wed 4/7/21	Tue 5/18/21								
196	BUILDING INTERIOR FINISHES	168 days	Wed 12/9/20	Fri 7/30/21								
197	Gymnasium Addition	69 days	Wed 12/9/20	Mon 3/15/21								
211	Classroom Addition	74 days	Mon 2/8/21	Thu 5/20/21								
222	Existing Building Renovation	111 days	Fri 2/26/21	Fri 7/30/21								
236	LANDSCAPING & SITEWORK COMPLETION	55 days	Mon 3/15/21	Fri 5/28/21								
242	FINAL TESTING AND PERMITTING	21 days	Wed 5/19/21	Wed 6/16/21								
248	COMMISSIONING & PUNCHLIST	20 days	Thu 7/1/21	Wed 7/28/21								
249	SUBSTANTIAL COMPLETION & CERTIFICATE OF OCCUPANCY	0 days	Wed 7/28/21	Wed 7/28/21								
250	OWNER MOVE-IN AND SETUP OF FF&E	40 days	Mon 7/5/21	Fri 8/27/21								
251	1st DAY OF SCHOOL	0 days	Mon 8/30/21	Mon 8/30/21								

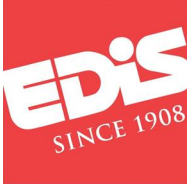

REQUEST FOR INFORMATION  
BID PACK A

TO: BOB GROVE, RG Architects

PRE-BID RFI#: 001

FROM: J.D. BARTLETT, EDiS COMPANY

DATE: 24 DECEMBER 2019

PROJECT: SILVER LAKE ELEMENTARY SCHOOL – ADDITIONS & RENOVATIONS

DWG. # / DETAIL: \_\_\_\_\_ SPEC. SECTIONS: 144200 PAGE: \_\_\_\_\_

**REQUEST:**

Submitted By: JD Bartlett/EDiS Company

Date: 24 December 2019

1.) Submitted Question.

Wheelchair Lifts – Basis of Design Manufacturer is no longer in business. Please provide alternative basis of design.

---

**RESPONSE:**

Specification Section 14 42 00, Section 2.2 A. shall read as follows:

2.2 VERTICAL PLATFORM LIFT

A. Unenclosed Vertical Wheelchair Platform Lift.

1. Basis-of-Design Product: Subject to compliance with requirements, provide Ascension Clarity 16E, or comparable product by one of the following:
  - a. Concord Elevator.
  - b. Garaventa Lift.
  - c. Inclinator Company of America.
  - d. Liftavator, Inc.

Response By: RAG

Date: 01/02/2019

---

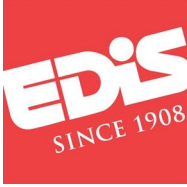

REQUEST FOR INFORMATION  
BID PACK A

TO: EDiS COMPANY PRE-BID RFI#: 002

FROM: J.D. BARTLETT, EDiS COMPANY DATE: 24 DECEMBER 2019

PROJECT: SILVER LAKE ELEMENTARY SCHOOL – ADDITIONS & RENOVATIONS

DWG. # / DETAIL: \_\_\_\_\_ SPEC. SECTIONS: 016200 PAGE: \_\_\_\_\_

**REQUEST:**

Submitted By: Union Wholesale Company Date: 24 December 2019

1.) Submitted Question.

Please clarify the substitution request submission deadline. Specification section 016200 Material and Equipment, Paragraph 6.C.2 specifies substitution requests are due at least 10 days prior to the date of the bid opening. Paragraph 6.C.3 specifies 7 days prior, as well as under 002113, Part 3.C Substitutions.

---

**RESPONSE:**

1.) Responses.

Substitution requests are due at least 7 days prior to the date of the bid opening. Refer to Addendum #2 for detailed revisions.

Response By: J.D. Bartlett, EDiS Company Date: 31 December 2019

---

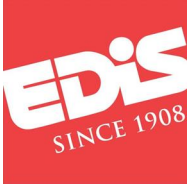

REQUEST FOR INFORMATION  
BID PACK A

TO: BOB GROVE, RG Architects

PRE-BID RFI#: 003

FROM: J.D. BARTLETT, EDiS COMPANY

DATE: 24 DECEMBER 2019

PROJECT: SILVER LAKE ELEMENTARY SCHOOL – ADDITIONS & RENOVATIONS

DWG. # / DETAIL: A90.A SPEC. SECTIONS: \_\_\_\_\_ PAGE: \_\_\_\_\_

**REQUEST:**

Submitted By: Old World Tile

Date: 24 December 2019

1.) Submitted Question.

Please reference sheet A90.A. We note that room 104 CAFETORIUM is called out to have wall tile finishes WT-1, WT-2, WT-3, and WT-4. However, no wall elevations showing the tile pattern are giving and elevations of this room show no wall tile. If this room is to have wall tile, can you please provide the wall tile pattern and the location and extent of wall tile in this room?

---

**RESPONSE:** Refer to sheet A92.A for wall tile patterns per drawings issued Addendum #1

1.) Responses.

Response By: Jordan Miller - BSA Date: 1/2/20

---



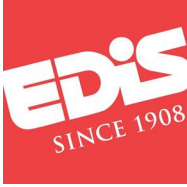

REQUEST FOR INFORMATION  
BID PACK A

TO: BOB GROVE, RG Architects

PRE-BID RFI#: 004

FROM: J.D. BARTLETT, EDiS COMPANY

DATE: 24 DECEMBER 2019

PROJECT: SILVER LAKE ELEMENTARY SCHOOL – ADDITIONS & RENOVATIONS

DWG. # / DETAIL: A90.A SPEC. SECTIONS: \_\_\_\_\_ PAGE: \_\_\_\_\_

**REQUEST:**

Submitted By: Old World Tile

Date: 24 December 2019

1.) Submitted Question.

Please reference sheet A90.A. Can you please provide the wall tile pattern for toilet 114? Sheet A90.A references WT8-12 but we note that there is no wall tile pattern with WT-8 though WT-12. Please clarify?

---

**RESPONSE:** Room 114 to have FRP per finish tag per drawings issued in Addendum #1; no wall tile identified for Room 114.

1.) Responses.

Response By: Jordan Miller - BSA Date: 1/2/20

---

---

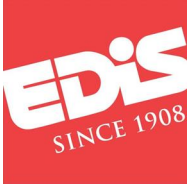

REQUEST FOR INFORMATION  
BID PACK A

TO: BOB GROVE, RG Architects

PRE-BID RFI#: 006

FROM: J.D. BARTLETT, EDiS COMPANY

DATE: 24 DECEMBER 2019

PROJECT: SILVER LAKE ELEMENTARY SCHOOL – ADDITIONS & RENOVATIONS

DWG. # / DETAIL: A90.A SPEC. SECTIONS: \_\_\_\_\_ PAGE: \_\_\_\_\_

**REQUEST:**

Submitted By: Old World Tile

Date: 24 December 2019

1.) Submitted Question.

Please reference sheet A90.A. Are we meant to use one of the pod corridor wall tile patterns in room 101? We note that WT-1-10 is referenced. Please clarify which pod pattern we are to use.

---

**RESPONSE:** Reference tie pattern 1/A92.A for wall tile pattern in Room 101 per drawings issued in Addendum #1

1.) Responses.

Response By: Jordan Miller - BSA Date: 1/2/20

---

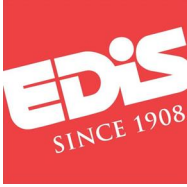

REQUEST FOR INFORMATION  
BID PACK A

TO: EDiS COMPANY PRE-BID RFI#: 007  
FROM: J.D. BARTLETT, EDiS COMPANY DATE: 24 DECEMBER 2019  
PROJECT: SILVER LAKE ELEMENTARY SCHOOL – ADDITIONS & RENOVATIONS  
DWG. # / DETAIL: \_\_\_\_\_ SPEC. SECTIONS: 001113, 260740 PAGE: \_\_\_\_\_

**REQUEST:**

Submitted By: Nickle Electrical Date: 24 December 2019

- 1.) In Silver Lake Elementary School, Volume 1 binder, section 001113m Advertisement for bid, it shows a dedicated contract for Structure Cable, but in Silver Lake Elementary School, Volume 3 binder, division 26 specifications, section 260740, Part 1 – General, 1.1 General Provisions, C., it states that the Electrical Contractor shall utilize an approved State of Delaware installing contractor for the network cabling. Will the Electrical Contractor be responsible for carrying the network cabling in their bid or will the network cabling systems specification section be part of the Structured Cable contract?

---

**RESPONSE:**

- 1.) Refer to Specification 011100 - Summary of Work. References to Structured Cable or Network cable should refer to "Structured Cable Contractor" not Electrical Contractor.

Response By: J.D. Bartlett, EDiS Company Date: 31 December 2019

---

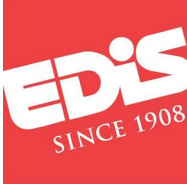

REQUEST FOR INFORMATION  
BID PACK A

TO: EDiS COMPANY PRE-BID RFI#: 008

FROM: J.D. BARTLETT, EDiS COMPANY DATE: 24 DECEMBER 2019

PROJECT: SILVER LAKE ELEMENTARY SCHOOL – ADDITIONS & RENOVATIONS

DWG. # / DETAIL: \_\_\_\_\_ SPEC. SECTIONS: 001113 PAGE: \_\_\_\_\_

**REQUEST:**

Submitted By: Nickle Electrical Date: 24 December 2019

- 1.) In Silver Lake Elementary School, Volume 1 binder, section 001113, Advertisement for Bid, it shows a dedicated contract for Special Systems, but in Silver Lake Elementary School, Volume 3 binder, division 26 specifications, there are sections for special systems, specifically 270731 Wireless Clock System, 260771 Intercom/Telecommunications and Clock Systems, and 260772 Cafetorium Sound Reinforcement System. Will the Electrical Contractor be responsible for carrying these special systems in their bid or will they be a part of the Special Systems contract?

---

**RESPONSE:**

- 1.) Refer to Specification 011100 - Summary of Work. References to Wireless Clock system or Intercom/Telecommunications and Clock System should refer to "Special Systems Contractor" not Electrical Contractor.

Response By: J.D. Bartlett, EDiS Company Date: 31 December 2019

---

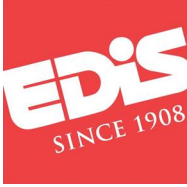

REQUEST FOR INFORMATION  
BID PACK A

TO: EDiS COMPANY PRE-BID RFI#: 009

FROM: J.D. BARTLETT, EDiS COMPANY DATE: 24 DECEMBER 2019

PROJECT: SILVER LAKE ELEMENTARY SCHOOL – ADDITIONS & RENOVATIONS

DWG. # / DETAIL: \_\_\_\_\_ SPEC. SECTIONS: \_\_\_\_\_ PAGE: \_\_\_\_\_

**REQUEST:**

Submitted By: Nickle Electrical Date: 24 December 2019

- 1.) Submitted Question.

Will the Site Contractor be responsible for repairs to existing asphalt and walkways caused during installation of site lighting or underground systems?

---

**RESPONSE:**

- 1.) Responses.

Refer to Addendum #2 for detailed revisions to the Summary of Work, which addresses this concern.

Response By: J.D. Bartlett, EDiS Company Date: 31 December 2019

---

---

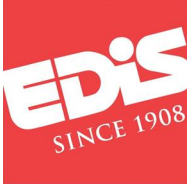

REQUEST FOR INFORMATION  
BID PACK A

TO: BOB GROVE, RG Architects

PRE-BID RFI#: 010

FROM: J.D. BARTLETT, EDiS COMPANY

DATE: 24 DECEMBER 2019

PROJECT: SILVER LAKE ELEMENTARY SCHOOL – ADDITIONS & RENOVATIONS

DWG. # / DETAIL: \_\_\_\_\_ SPEC. SECTIONS: \_\_\_\_\_ PAGE: \_\_\_\_\_

**REQUEST:**

Submitted By: Nickle Electrical

Date: 24 December 2019

- 1.) Submitted Question.

Will Lightspeed or Epic be used for typical classroom sound?

---

**RESPONSE:**

- 1.) Responses.

The Epic Platform will be used.

Response By: Douglas M Green – Furlow Associates, Inc. Date: 12/26/19

---

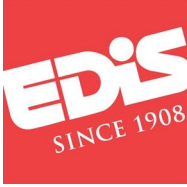

REQUEST FOR INFORMATION  
BID PACK A

TO: EDiS COMPANY PRE-BID RFI#: 011

FROM: J.D. BARTLETT, EDiS COMPANY DATE: 24 DECEMBER 2019

PROJECT: SILVER LAKE ELEMENTARY SCHOOL – ADDITIONS & RENOVATIONS

DWG. # / DETAIL: \_\_\_\_\_ SPEC. SECTIONS: \_\_\_\_\_ PAGE: \_\_\_\_\_

**REQUEST:**

Submitted By: D. Shinn, Inc. Date: 24 December 2019

- 1.) Submitted Question.

The roofing demo on the portions of the building that will be left standing is to be handled by the roofer? Roofing package should include for dumpsters and demo of existing in those areas? Please clarify.

---

**RESPONSE:**

- 1.) Responses.

Refer to Addendum #2 for detailed revisions clarifying the demolition responsibilities of the Roof Contractor.

Response By: J.D. Bartlett, EDiS Company Date: 31 December 2019

---

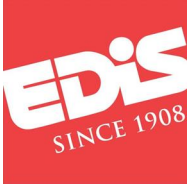

REQUEST FOR INFORMATION  
BID PACK A

TO: BOB GROVE, RG Architects

PRE-BID RFI#: 012

FROM: J.D. BARTLETT, EDiS COMPANY

DATE: 24 DECEMBER 2019

PROJECT: SILVER LAKE ELEMENTARY SCHOOL – ADDITIONS & RENOVATIONS

DWG. # / DETAIL: A92.A Elevation 3 SPEC. SECTIONS:      PAGE:     

**REQUEST:**

Submitted By: Old World Tile Date: 24 December 2019

- 1.) Please reference sheet A92.A Elevation 3 in the SLES Drawings Combined. Can you please give the specification for the metal top edge found at the base? Please name product and finish. Please also clarify who is responsible for installation. I would assume it is contract A-16. Is this correct?

---

**RESPONSE:**

- 1.) Provide Schluter “Deco-SG 100 AE 12” or approved equal. Finish to be “Satin Anodized Aluminum”. Refer to Specification Section 011100 Summary of Work, Contract A-16 - Ceramic Tile is responsible for providing metal trim pieces integral to the tile installations.

Response By: Jordan Miller – BSA / J.D. Bartlett, EDiS Company Date: 1/2/20

---



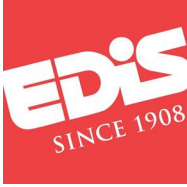

REQUEST FOR INFORMATION  
BID PACK A

TO: BOB GROVE, RG Architects

PRE-BID RFI#: 013

FROM: J.D. BARTLETT, EDiS COMPANY

DATE: 24 DECEMBER 2019

PROJECT: SILVER LAKE ELEMENTARY SCHOOL – ADDITIONS & RENOVATIONS

DWG. # / DETAIL: A92.A SPEC. SECTIONS: \_\_\_\_\_ PAGE: \_\_\_\_\_

**REQUEST:**

Submitted By: Old World Tile

Date: 24 December 2019

1.) Submitted Question.

Please reference sheet A92.A. Can you confirm that the metal edge at the top of base referenced in elevation 7 is applicable to elevation 5 and 6?

---

**RESPONSE:**

Yes, metal edge at top of base is also applicable in elevation 5 and 6.

Provide Schluter “Deco-SG 125 AE 12” or approved equal. Finish to be “Satin Anodized Aluminum”.

1.) Responses.

Response By: Jordan Miller - BSA Date: 1/2/20

---

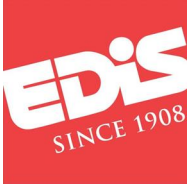

REQUEST FOR INFORMATION  
BID PACK A

TO: BOB GROVE, RG Architects

PRE-BID RFI#: 014

FROM: J.D. BARTLETT, EDiS COMPANY

DATE: 24 DECEMBER 2019

PROJECT: SILVER LAKE ELEMENTARY SCHOOL – ADDITIONS & RENOVATIONS

DWG. # / DETAIL: A92.A SPEC. SECTIONS: \_\_\_\_\_ PAGE: \_\_\_\_\_

**REQUEST:**

Submitted By: Old World Tile

Date: 24 December 2019

1.) Submitted Question.

Please clarify how outside corners of tile as are to be treated. I would assume they would get capped with a schluter metal edge trim as seen in sheet A92.A in both halls and bathrooms. Is this correct? Can you give the specifications for this trim, both product and finish?

---

**RESPONSE:** Outside corners in all areas to receive Schluter Rondec or approved equal. All exposed edges to receive Schluter (or approved equal) item numbers including but not limited to; EV, IV, E2L, I2L, I2S. All trim to be finished in Anodized Aluminum Brushed Nickel.

Full Height WT-12 – WT-15:

Rondec 125 – 1/2" (RO125ATGB) w/ matching inside and outside corners & all required trim accessories

Wainscot WT-1 - WT-11:

Rondec 100 – 3/8" (RO100ATGB) w/ matching inside and outside corners & all required trim accessories

1.) Responses.

Response By: Jordan Miller - BSA Date: 1/2/20

---

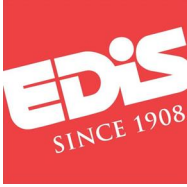

REQUEST FOR INFORMATION  
BID PACK A

TO: BOB GROVE, RG Architects

PRE-BID RFI#: 015

FROM: J.D. BARTLETT, EDiS COMPANY

DATE: 24 DECEMBER 2019

PROJECT: SILVER LAKE ELEMENTARY SCHOOL – ADDITIONS & RENOVATIONS

DWG. # / DETAIL: A92.A SPEC. SECTIONS: \_\_\_\_\_ PAGE: \_\_\_\_\_

**REQUEST:**

Submitted By: Old World Tile

Date: 24 December 2019

1.) Submitted Question.

Please reference sheet A92.A Elevation 1 and 2. What is the intent at the rubber base. Is the rubber base to be installed over the ceramic tile or are we to cut the tile to the rubber base? Please clarify.

---

**RESPONSE:** Per drawings issued in Addendum #1, the rubber base as indicated on 1/A92.A and 2/A92.A is to be installed over ceramic tile.

1.) Responses.

Response By: Jordan Miller - BSA Date: 1/2/20

---

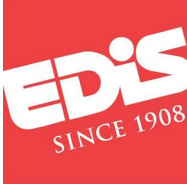

REQUEST FOR INFORMATION  
BID PACK A

TO: BOB GROVE, RG Architects

PRE-BID RFI#: 016

FROM: J.D. BARTLETT, EDiS COMPANY

DATE: 24 DECEMBER 2019

PROJECT: SILVER LAKE ELEMENTARY SCHOOL – ADDITIONS & RENOVATIONS

DWG. # / DETAIL: \_\_\_\_\_ SPEC. SECTIONS: 093000 PAGE: \_\_\_\_\_

**REQUEST:**

Submitted By: Old World Tile

Date: 24 December 2019

1.) Submitted Question.

Please reference spec section 09 30 00. We note that multiple grouts have been named such as Latex-Portland Cement Grout, epoxy grout, and water based urethane grout but that only water based urethane grout has been specified for installation. We believe this may be an over specification which will result in an unnecessary significantly higher material and labor cost considering the type of work being done and the type of tile being used. Can the Water based Urethane grout be removed from the installation method found in 09 30 00 - 12 and be replaced with Latex-Portland Cement Grout.

---

**RESPONSE:** Yes, Latex-Portland Cement Grout can replace Water Based Urethane Grout in the installation method.

1.) Responses.

Response By: Jordan Miller - BSA Date: 1/2/20

---

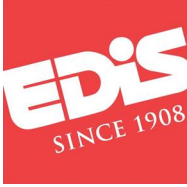

REQUEST FOR INFORMATION  
BID PACK A

TO: BOB GROVE, RG Architects

PRE-BID RFI#: 017

FROM: J.D. BARTLETT, EDiS COMPANY

DATE: 24 DECEMBER 2019

PROJECT: SILVER LAKE ELEMENTARY SCHOOL – ADDITIONS & RENOVATIONS

DWG. # / DETAIL: A90.D SPEC. SECTIONS: \_\_\_\_\_ PAGE: \_\_\_\_\_

**REQUEST:**

Submitted By: Old World Tile

Date: 24 December 2019

1.) Submitted Question.

Please reference sheet A90.D in drawings. There is an unidentified wall tile at the top of the Material Schedule. We cannot find any elevations or notes that referenced this unidentified finish or tile size in the drawings or specs. Is this tile finish relevant to the current scope of work for contract A-16?

---

**RESPONSE:** Refer to A90.D issued in Addendum #1, no unidentified wall tile remains.

1.) Responses.

Response By: Jordan Miller - BSA Date: 1/2/20

---

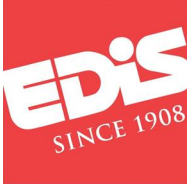

REQUEST FOR INFORMATION  
BID PACK A

TO: BOB GROVE, RG Architects

PRE-BID RFI#: 018

FROM: J.D. BARTLETT, EDiS COMPANY

DATE: 24 DECEMBER 2019

PROJECT: SILVER LAKE ELEMENTARY SCHOOL – ADDITIONS & RENOVATIONS

DWG. # / DETAIL: A92.A Elevation 1 SPEC. SECTIONS: \_\_\_\_\_ PAGE: \_\_\_\_\_

**REQUEST:**

Submitted By: Old World Tile

Date: 24 December 2019

1.) Submitted Question.

Please reference sheet A92.A Elevation 1. Can you confirm that the 1st and 3rd accent stripe in the tile pattern is random with respect to the placement of WT-2, WT-3, WT-4, and WT-8 with an equal amount of each accent tile?

---

**RESPONSE:**

Refer to drawings issued in Addendum no. 1.

3<sup>rd</sup> accent stripe is not visible in drawings. Clarification may be necessary for proper response.

1.) Responses.

Response By: \_\_\_\_\_ Date: \_\_\_\_\_

---

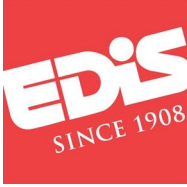

REQUEST FOR INFORMATION  
BID PACK A

TO: BOB GROVE, RG Architects PRE-BID RFI#: 019

FROM: J.D. BARTLETT, EDiS COMPANY DATE: 24 DECEMBER 2019

PROJECT: SILVER LAKE ELEMENTARY SCHOOL – ADDITIONS & RENOVATIONS

DWG. # / DETAIL: \_\_\_\_\_ SPEC. SECTIONS: \_\_\_\_\_ PAGE: \_\_\_\_\_

**REQUEST:**

Submitted By: Brandywine Contractors, Inc. Date: 24 December 2019

1.) Submitted Question.

Regarding the structural drawings, referring to the Drawing Index on drawing 0.2, there are numerous duplicate numbers but only a single drawing for each number.

Also, drawings S503 and S601 is missing from the bid set.

---

---

**RESPONSE:**

- 1.) Drawing list issue with duplicated items has been corrected. Sheet 0.2 will be re-issued with addendum #2
- 2.) Sheets S503 and S601 were listed by mistake; they do not exist and have been deleted from the drawing list.

Response By: Oscar Enderica - RGA Date: 1/2/2020

---

---

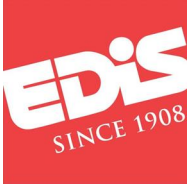

REQUEST FOR INFORMATION  
BID PACK A

TO: BOB GROVE, RG Architects

PRE-BID RFI#: 020

FROM: J.D. BARTLETT, EDiS COMPANY

DATE: 26 DECEMBER 2019

PROJECT: SILVER LAKE ELEMENTARY SCHOOL – ADDITIONS & RENOVATIONS

DWG. # / DETAIL: \_\_\_\_\_ SPEC. SECTIONS: \_\_\_\_\_ PAGE: \_\_\_\_\_

**REQUEST:**

Submitted By: Tri-State Carpet

Date: 26 December 2019

1.) Submitted Question.

Base bid for the Gymnasium Floor is LVT (as see in the Alternates and not the finish plans)

- o It does not clarify which LVT(s) to use.
- o Does Fitness 503 follow this same base bid / alternate flooring plan?

---

**RESPONSE:**

Product and manufacturer to be determined.

Fitness (503) follows same flooring as the gymnasium in base bid/ alternate

1.) Responses.

Response By: Jordan Miller - BSA Date: 1/2/2020

---



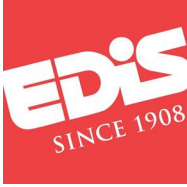

REQUEST FOR INFORMATION  
BID PACK A

TO: EDiS COMPANY PRE-BID RFI#: 023

FROM: J.D. BARTLETT, EDiS COMPANY DATE: 26 DECEMBER 2019

PROJECT: SILVER LAKE ELEMENTARY SCHOOL – ADDITIONS & RENOVATIONS

DWG. # / DETAIL: \_\_\_\_\_ SPEC. SECTIONS: \_\_\_\_\_ PAGE: \_\_\_\_\_

**REQUEST:**

Submitted By: Tri-State Carpet Date: 26 December 2019

- 1.) Submitted Question.

Can an allowance be given for floor prep as the current floor has not been demoed to see the amount of prep needed?

---

**RESPONSE:**

- 1.) Responses.

An allowance has been added to Contract No. A-14 - Flooring, to address floor prep in locations where existing slabs will remain. Refer to Addendum #2 for details.

Response By: J.D. Bartlett, EDiS Company Date: 31 December 2019

---

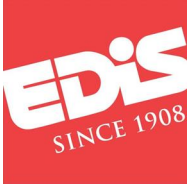

REQUEST FOR INFORMATION  
BID PACK A

TO: BOB GROVE, RG Architects

PRE-BID RFI#: 024

FROM: J.D. BARTLETT, EDiS COMPANY

DATE: 26 DECEMBER 2019

PROJECT: SILVER LAKE ELEMENTARY SCHOOL – ADDITIONS & RENOVATIONS

DWG. # / DETAIL: A90.B SPEC. SECTIONS: \_\_\_\_\_ PAGE: \_\_\_\_\_

**REQUEST:**

Submitted By: Tri-State Carpet

Date: 26 December 2019

1.) Submitted Question.

Media Center 132 (A90.B)

- Is there a legend for the 4 different types of carpets?
- Is LVT 3 or LVT 5 to be used?

---

**RESPONSE:**

LVT-5 to be used in the Media Center. Refer to sheet A90.B in Addendum no. 2.

1.) Responses.

Response By: Jordan Miller - BSA Date: 1/2/2020

---

---

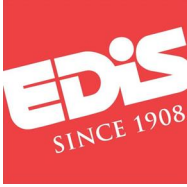

REQUEST FOR INFORMATION  
BID PACK A

TO: BOB GROVE, RG Architects

PRE-BID RFI#: 025

FROM: J.D. BARTLETT, EDiS COMPANY

DATE: 26 DECEMBER 2019

PROJECT: SILVER LAKE ELEMENTARY SCHOOL – ADDITIONS & RENOVATIONS

DWG. # / DETAIL: \_\_\_\_\_ SPEC. SECTIONS: \_\_\_\_\_ PAGE: \_\_\_\_\_

**REQUEST:**

Submitted By: Tri-State Carpet

Date: 26 December 2019

1.) Submitted Question.

Commons 213 is RB 2 or **MRB 2** to be used?

---

**RESPONSE:** MRB-2 is to be used

1.) Responses.

Response By: Jordan Miller - BSA Date: 1/2/2020

---

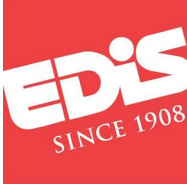

REQUEST FOR INFORMATION  
BID PACK A

TO: BOB GROVE, RG Architects

PRE-BID RFI#: 026

FROM: J.D. BARTLETT, EDiS COMPANY

DATE: 26 DECEMBER 2019

PROJECT: SILVER LAKE ELEMENTARY SCHOOL – ADDITIONS & RENOVATIONS

DWG. # / DETAIL: A90 SPEC. SECTIONS: \_\_\_\_\_ PAGE: \_\_\_\_\_

**REQUEST:**

Submitted By: Tri-State Carpet

Date: 26 December 2019

1.) Submitted Question.

Patterns needed

- o A90.A – Corridor 119 (VT1-3), Breakroom 123 (VT1-2)
- o A90.B – Resource / Faculty Rooms, 3 of each (VT1-3), Comm Support (VT 1-4), Tech/Stem 134-135 (VT1-7), OT/PT & Speech 411 & 410 (VT 1-3), Cots 611 (SV 1-2)
- o A90.C - Resource / Faculty Rooms, 2 of each (VT1-3), ESL 316 (VT 1-3), Storage 332 (VT1-2)

---

**RESPONSE:**

Reference sheets A90.A, A90.B, and A90.C issued in Addendum no. 2 for pattern identifications.

1.) Responses.

Response By: Jordan Miller - BSA Date: 1/2/2020

---

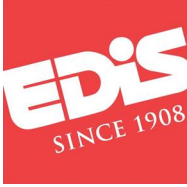

REQUEST FOR INFORMATION  
BID PACK A

TO: EDiS COMPANY PRE-BID RFI#: 027

FROM: J.D. BARTLETT, EDiS COMPANY DATE: 27 DECEMBER 2019

PROJECT: SILVER LAKE ELEMENTARY SCHOOL – ADDITIONS & RENOVATIONS

DWG. # / DETAIL: A06 SPEC. SECTIONS: \_\_\_\_\_ PAGE: \_\_\_\_\_

**REQUEST:**

Submitted By: Reed Associates Date: 27 December 2019

- 1.) With the stage flooring being supplied by Contract A14, the stair treads/risers by A06, and the stage front by A10, there is always the issue of the stage overhang (HIGHLIGHTED ON THE ATTACHED DRAWING) and who is to supply this. The other issue is you will have is trying to match finishes by 3 different contracts will be extremely difficult.

---

---

**RESPONSE:**

- 1.) Refer to Addendum #2 for detailed revisions clarifying the scope and interface of scope for contracts responsible for his work.

Response By: J.D. Bartlett, EDiS Company Date: 31 December 2019

---

---

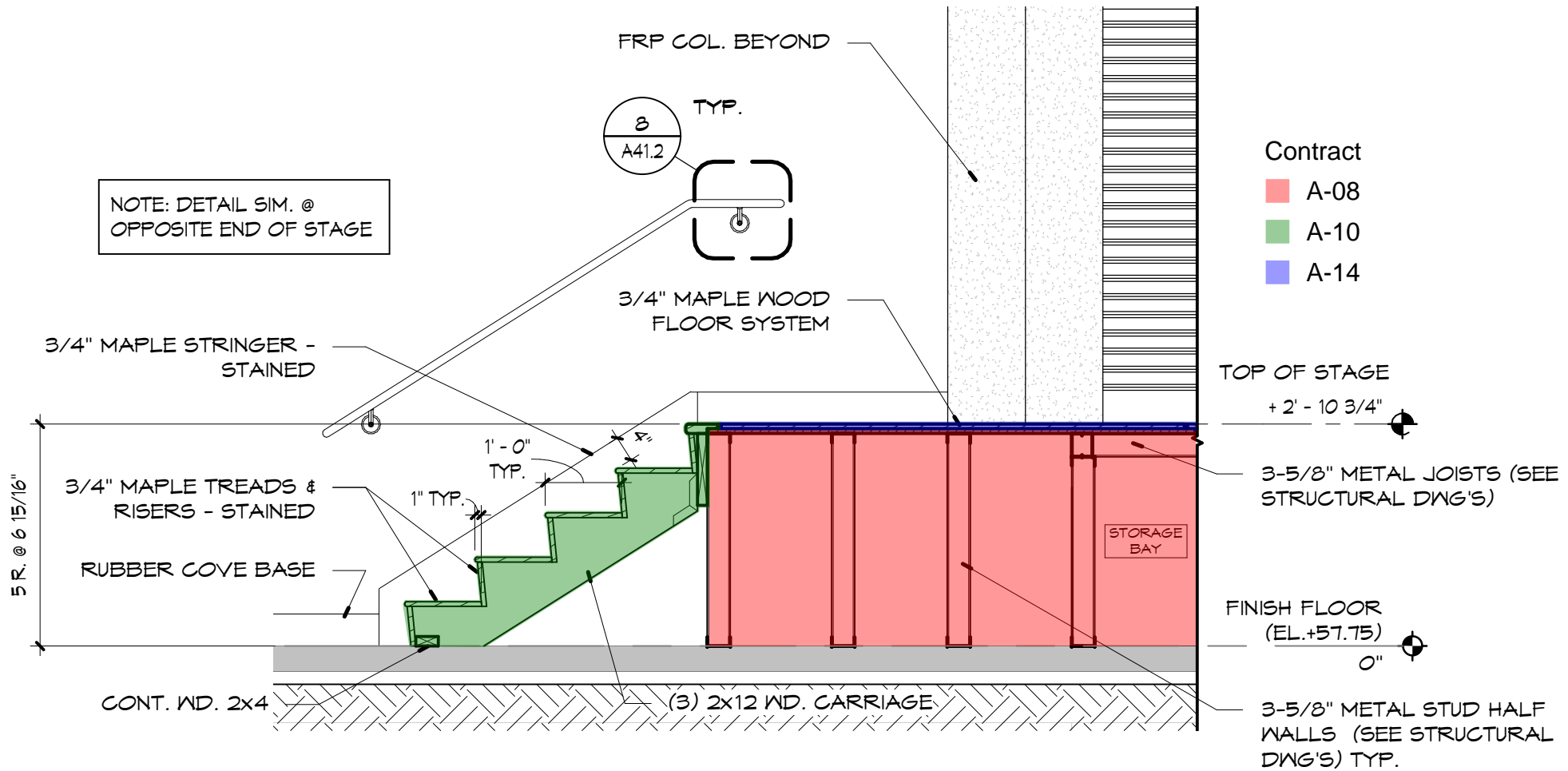

**2**

**SECTION @ STAGE STAIR**

1/2" = 1'-0"

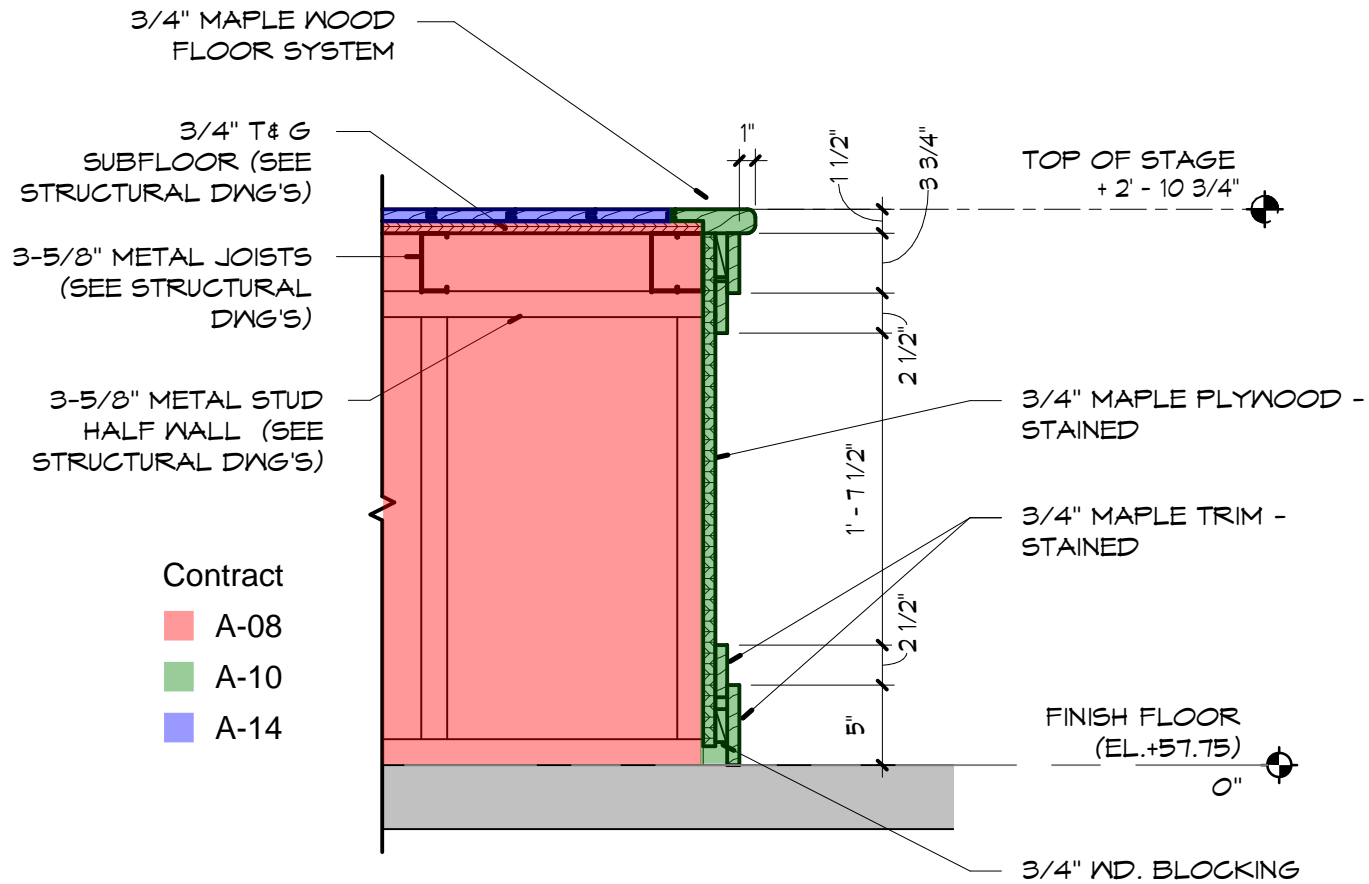

**6** DETAIL @ STAGE FRONT

1" = 1'-0"

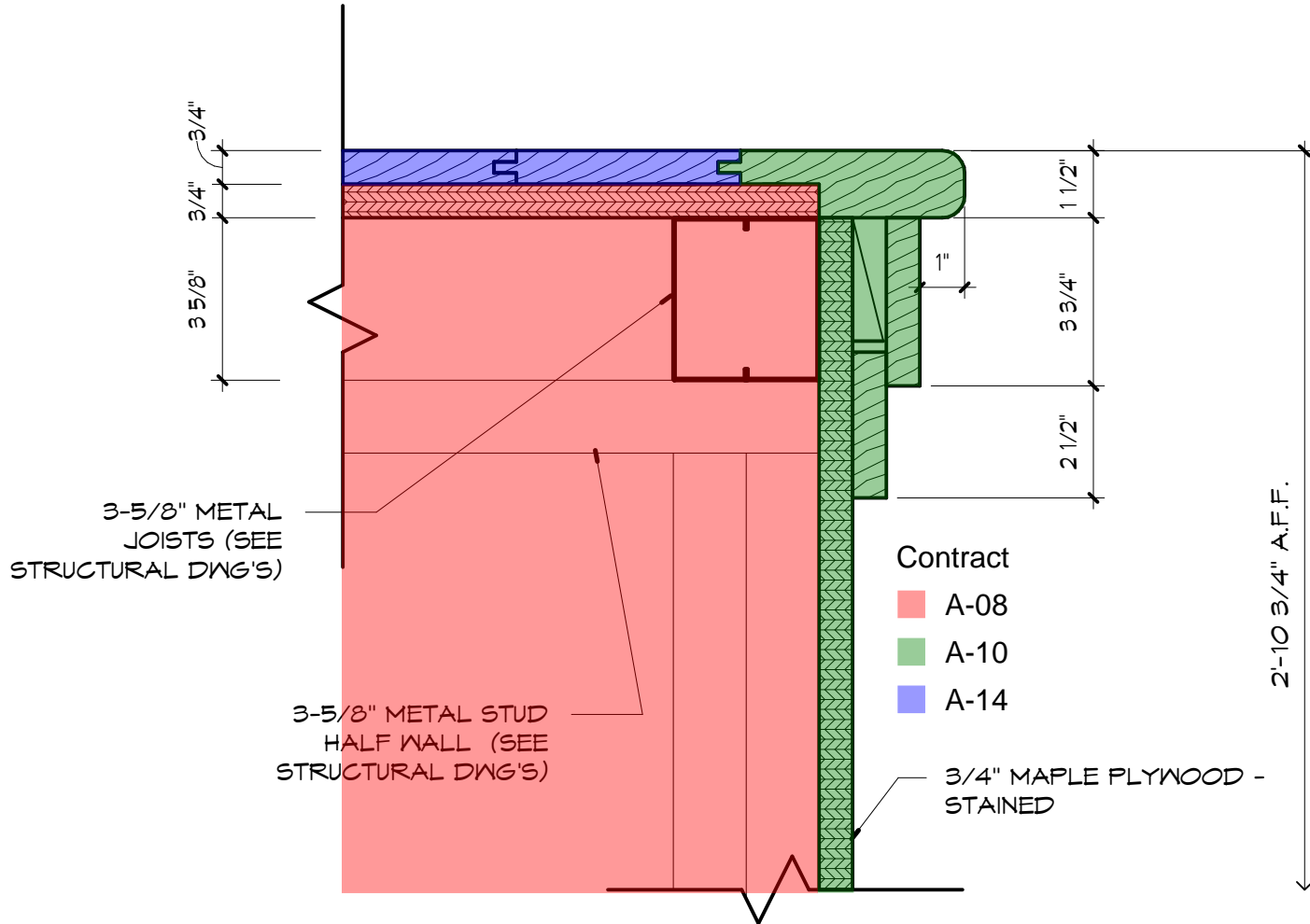

DETAIL BEYOND DOOR HEAD

**H24** HEAD DETAIL @ STORAGE BENEATH STAGE

3" = 1'-0"



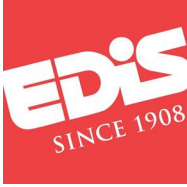

REQUEST FOR INFORMATION  
BID PACK A

TO: BOB GROVE, RG Architects

PRE-BID RFI#: 029

FROM: J.D. BARTLETT, EDiS COMPANY

DATE: 27 DECEMBER 2019

PROJECT: SILVER LAKE ELEMENTARY SCHOOL – ADDITIONS & RENOVATIONS

DWG. # / DETAIL: \_\_\_\_\_ SPEC. SECTIONS: 62023 PAGE: \_\_\_\_\_

**REQUEST:**

Submitted By: Reed Associates

Date: 27 December 2019

- 1.) Submitted Question.

Section 62023 calls for window sills with aprons. Plan details do not show any aprons. Please confirm aprons are not needed?

---

**RESPONSE:**

- 1.) Yes, aprons will be incorporated in the window sill. Details will be included with Addendum #2.

Response By: Oscar Enderica - RGA Date: 1/2/2020

---

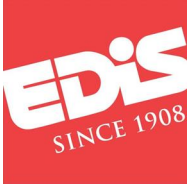

REQUEST FOR INFORMATION  
BID PACK A

TO: BOB GROVE, RG Architects

PRE-BID RFI#: 031

FROM: J.D. BARTLETT, EDiS COMPANY

DATE: 27 DECEMBER 2019

PROJECT: SILVER LAKE ELEMENTARY SCHOOL – ADDITIONS & RENOVATIONS

DWG. # / DETAIL: \_\_\_\_\_ SPEC. SECTIONS: \_\_\_\_\_ PAGE: \_\_\_\_\_

**REQUEST:**

Submitted By: Reed Associates

Date: 27 December 2019

- 1.) Submitted Question.

Finish schedule shows 2 colors for solid surface but does not state which color is to be used for window sills. please provide this color.

---

**RESPONSE:**

Refer to finish schedule per Addendum # 2. SS3 – Corian “Dove” to be used at solid surface sills.

- 1.) Responses.

Response By: Jordan Miller - BSA Date: 1/2/2020

---

---

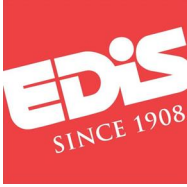

REQUEST FOR INFORMATION  
BID PACK A

TO: BOB GROVE, RG Architects

PRE-BID RFI#: 032

FROM: J.D. BARTLETT, EDiS COMPANY

DATE: 27 DECEMBER 2019

PROJECT: SILVER LAKE ELEMENTARY SCHOOL – ADDITIONS & RENOVATIONS

DWG. # / DETAIL: 13/A91.C SPEC. SECTIONS: \_\_\_\_\_ PAGE: \_\_\_\_\_

**REQUEST:**

Submitted By: Reed Associates

Date: 27 December 2019

1.) Submitted Question.

Elevation 13/A91.C calls for the transaction top to be SS3. There is no SS3. Please confirm this is to be SS1 per finish schedule?

---

**RESPONSE:** Correct, transaction top to be SS1 per finish schedule.

1.) Responses.

Response By: Jordan Miller - BSA Date: 1/2/2020

---

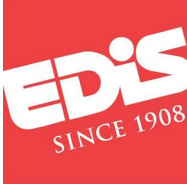

REQUEST FOR INFORMATION  
BID PACK A

TO: BOB GROVE, RG Architects

PRE-BID RFI#: 033

FROM: J.D. BARTLETT, EDiS COMPANY

DATE: 27 DECEMBER 2019

PROJECT: SILVER LAKE ELEMENTARY SCHOOL – ADDITIONS & RENOVATIONS

DWG. # / DETAIL: 14/A91.C SPEC. SECTIONS: \_\_\_\_\_ PAGE: \_\_\_\_\_

**REQUEST:**

Submitted By: Reed Associates

Date: 27 December 2019

- 1.) Submitted Question.

Elevation 14/A91.C calls for field applied tack surface for the media center desk. Please confirm these are NOT by contract A06. This also applies to the Reception desk in elevation 15/A91.D

---

**RESPONSE:**

- 1.) Field applied tack boards at the media center desk & main receptions desk (Interior Elevations 14/A91.C & 15/A91.D respectively) shall be the responsibility of Contract A-10 Casework and Millwork.

Response By: J.D. Bartlett, EDiS Company Date: 03 January 2020

---

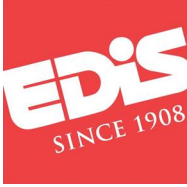

REQUEST FOR INFORMATION  
BID PACK A

TO: BOB GROVE, RG Architects PRE-BID RFI#: 034

FROM: J.D. BARTLETT, EDiS COMPANY DATE: 27 DECEMBER 2019

PROJECT: SILVER LAKE ELEMENTARY SCHOOL – ADDITIONS & RENOVATIONS

DWG. # / DETAIL: 5/A91.F SPEC. SECTIONS: \_\_\_\_\_ PAGE: \_\_\_\_\_

**REQUEST:**

Submitted By: Reed Associates Date: 27 December 2019

1.) Submitted Question.

Section 5/A91.F calls for solid surface countertop and apron at ADA station. Please note all ADA sink stations are in the middle of casework runs with plam countertops noted for every elevation. Please clarify if there will need to be a single solid surface top/apron with plam countertops on either side of this unit. If this is the case, this raises the probability of water damage to the countertops on either side of the sink unit with a seam of two different materials within inches of the sink.

---

---

**RESPONSE:**

Countertop in Treatment Room (614) to be SS as indicated on drawings. Refer to sheet A91.F per Addendum # 2 for drawings.

1.) Responses.

Response By: Jordan Miller - BSA Date: 1/2/2020

---

---

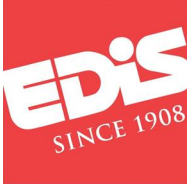

REQUEST FOR INFORMATION  
BID PACK A

TO: BOB GROVE, RG Architects

PRE-BID RFI#: 035

FROM: J.D. BARTLETT, EDiS COMPANY

DATE: 27 DECEMBER 2019

PROJECT: SILVER LAKE ELEMENTARY SCHOOL – ADDITIONS & RENOVATIONS

DWG. # / DETAIL: \_\_\_\_\_ SPEC. SECTIONS: 123200 PAGE: \_\_\_\_\_

**REQUEST:**

Submitted By: Reed Associates

Date: 27 December 2019

1.) Submitted Question.

Finish schedule and elevations call for plastic laminate countertops at all locations. Section 123200 calls for solid surface. Please clarify which is to be provided. If plastic laminate, what material is to be used on the front edge, 3mm pvc or the same laminate as used on the horizontal surface?

---

**RESPONSE:**

Plastic laminate countertops edges are to receive 3mm PVC to match.

1.) Responses.

Response By: Jordan Miller - BSA Date: 1/2/2020

---

---

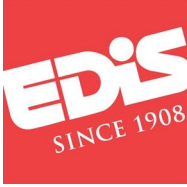

REQUEST FOR INFORMATION  
BID PACK A

TO: EDiS COMPANY PRE-BID RFI#: 042

FROM: J.D. BARTLETT, EDiS COMPANY DATE: 30 DECEMBER 2019

PROJECT: SILVER LAKE ELEMENTARY SCHOOL – ADDITIONS & RENOVATIONS

DWG. # / DETAIL: \_\_\_\_\_ SPEC. SECTIONS: 093000 PAGE: \_\_\_\_\_

**REQUEST:**

Submitted By: Old World Tile Date: 30 December 2019

- 1.) Scope of work Line item 4 in contract A-16 references waterproofing and anti-fracture membrane at all tile locations as specified by project documents. Line item 7 references crack suppression membrane for tile installation. Line item 3 references Vapor retarding where applicable. Can all three of these line items be removed from scope of work? Neither are required per specified installation method W243 found in 09 30 00. Furthermore, waterproofing is not possible due to no tight floor-wall connection being made since tile is not being installed on the floors. The waterproofing is already made with resinous floor and resinous base.

---

**RESPONSE:**

- 1.) Refer to Addendum #2 for detailed revisions clarifying the responsibilities of Contract A-16 - Ceramic Tile.

Response By: J.D. Bartlett, EDiS Company Date: 31 December 2019

---

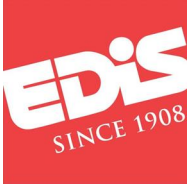

REQUEST FOR INFORMATION  
BID PACK A

TO: EDiS COMPANY PRE-BID RFI#: 043

FROM: J.D. BARTLETT, EDiS COMPANY DATE: 30 DECEMBER 2019

PROJECT: SILVER LAKE ELEMENTARY SCHOOL – ADDITIONS & RENOVATIONS

DWG. # / DETAIL: \_\_\_\_\_ SPEC. SECTIONS: 011100-60 PAGE: \_\_\_\_\_

**REQUEST:**

Submitted By: Old World Tile Date: 30 December 2019

1.) Submitted Question.

Please reference 011100-60 line item 8 found in addendum 1 which references cementitious backer units as part as contracts A-16 scope of work. Can you please remove line item 8 from contract A-16 scope of work. This should be under carpenters scope of work.

---

**RESPONSE:**

1.) Responses.

Correct. Refer to Addendum #2 for detailed revisions clarifying the responsibilities of Contract A-16 - Ceramic Tile.

Response By: J.D. Bartlett, EDiS Company Date: 31 December 2019

---



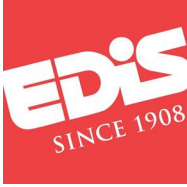

REQUEST FOR INFORMATION  
BID PACK A

TO: EDiS COMPANY PRE-BID RFI#: 044

FROM: J.D. BARTLETT, EDiS COMPANY DATE: 30 DECEMBER 2019

PROJECT: SILVER LAKE ELEMENTARY SCHOOL – ADDITIONS & RENOVATIONS

DWG. # / DETAIL: \_\_\_\_\_ SPEC. SECTIONS: 011100-60 PAGE: \_\_\_\_\_

**REQUEST:**

Submitted By: Old World Tile Date: 30 December 2019

- 1.) Please reference 011100-60 line item 6 found in addendum 1 which references leveling and patching. To my understanding, all if not most walls in Silver Lake are to receive new studs and dry walls. Furthermore, Contract A-16 owns no ceramic floors. Can line item 6 be removed from scope of work or a small allowance be placed in the bid for patching and repair of field conditions/deficient work by the steel stud and drywall contractor?

---

**RESPONSE:**

- 1.) Refer to Addendum #2 for detailed revisions clarifying the responsibilities of Contract A-16 - Ceramic Tile.

Response By: J.D. Bartlett, EDiS Company Date: 31 December 2019

---

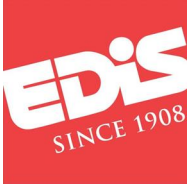

REQUEST FOR INFORMATION  
BID PACK A

TO: EDiS COMPANY PRE-BID RFI#: 048

FROM: J.D. BARTLETT, EDiS COMPANY DATE: 30 DECEMBER 2019

PROJECT: SILVER LAKE ELEMENTARY SCHOOL – ADDITIONS & RENOVATIONS

DWG. # / DETAIL: \_\_\_\_\_ SPEC. SECTIONS: \_\_\_\_\_ PAGE: \_\_\_\_\_

**REQUEST:**

Submitted By: Thompson & Sons Contracting Date: 30 December 2019

1.) Submitted Question.

Clarification is needed on the concrete portion of site work portion. Typically, the footers for the concrete is completed by the Concrete subcontractor and per the scope it's stating the pricing for footers is to be given by the Site contractor. Need to determine our pricing so we need to know how we're to determine how much foundation can be done a day and how many days it will take for the concrete contractor to complete their portion of work.

---

---

**RESPONSE:**

1.) Responses.

Refer to Addendum #2 for detailed revisions clarifying the responsibilities of Contract A-02 - Sitework & A-03 - Concrete.

Response By: J.D. Bartlett, EDiS Company Date: 31 December 2019

---

---



REQUEST FOR INFORMATION  
BID PACK A

TO: EDiS COMPANY PRE-BID RFI#: 049

FROM: J.D. BARTLETT, EDiS COMPANY DATE: 31 DECEMBER 2019

PROJECT: SILVER LAKE ELEMENTARY SCHOOL – ADDITIONS & RENOVATIONS

DWG. # / DETAIL: \_\_\_\_\_ SPEC. SECTIONS: \_\_\_\_\_ PAGE: \_\_\_\_\_

**REQUEST:**

Submitted By: Mid-Atlantic Electrical Services, Inc. Date: 31 December 2019

- 1.) Please advise how alternates' 5a, 5b, 7, 8, and 9 affect the electrical bid per electrical bid form. Drawings do not show any electrical changes associated with these alternates.

---

**RESPONSE:**

- 1.) Refer to updated bid form, published in Addendum #2.

Response By: J.D. Bartlett, EDiS Company Date: 03 January 2020

---

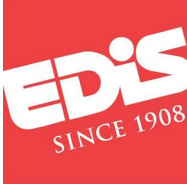

REQUEST FOR INFORMATION  
BID PACK A

TO: EDiS COMPANY PRE-BID RFI#: 050  
FROM: J.D. BARTLETT, EDiS COMPANY DATE: 02 JANUARY 2020  
PROJECT: SILVER LAKE ELEMENTARY SCHOOL – ADDITIONS & RENOVATIONS  
DWG. # / DETAIL: \_\_\_\_\_ SPEC. SECTIONS: \_\_\_\_\_ PAGE: \_\_\_\_\_

**REQUEST:**

Submitted By: Thompson & Sons Contracting Date: 02 January 2020

- 1.) What is the duration of the project? Questions was asked by our fencing subcontractors when giving pricing for Temp Fencing.

---

---

**RESPONSE:**

- 1.) Refer to the pre-bid meeting minutes for overall construction window. Construction is scheduled to begin in March 2020 and substantial completion by June 30, 2021. A more comprehensive schedule will be included as an attachment to Addendum #2.

Response By: J.D Bartlett, EDiS Company Date: 02 January 2020

---

---

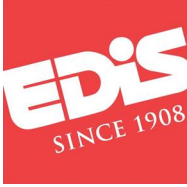

REQUEST FOR INFORMATION  
BID PACK A

TO: EDiS COMPANY PRE-BID RFI#: 051  
FROM: J.D. BARTLETT, EDiS COMPANY DATE: 02 JANUARY 2020  
PROJECT: SILVER LAKE ELEMENTARY SCHOOL – ADDITIONS & RENOVATIONS  
DWG. # / DETAIL: \_\_\_\_\_ SPEC. SECTIONS: \_\_\_\_\_ PAGE: \_\_\_\_\_

**REQUEST:**

Submitted By: Brandywine Contractors, Inc. Date: 02 January 2020

1.) Submitted Question.

Contract #8 – Metal Studs & Drywall scope bullet note #17 indicates for contract #8 to provide architectural expansion joint systems. Bullet note #40 within same scope indicates Carpentry & General works contract to provide architectural expansion joint covers. Contract #5 – Carpentry & General Work does not include and spec or narrative for these. Please confirm which package owns.

---

**RESPONSE:**

1.) Responses.

Refer to Addendum #2 for detailed revisions clarifying the responsibilities of Contract A-6 - Carpentry & General Work and Contract A-8 - Metal Studs & Drywall, specifically related to expansion joint scope.

Response By: J.D. Bartlett, EDiS Company Date: 02 January 2020

---

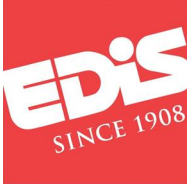

REQUEST FOR INFORMATION  
BID PACK A

TO: EDiS COMPANY PRE-BID RFI#: 052  
FROM: J.D. BARTLETT, EDiS COMPANY DATE: 02 JANUARY 2020  
PROJECT: SILVER LAKE ELEMENTARY SCHOOL – ADDITIONS & RENOVATIONS  
DWG. # / DETAIL: \_\_\_\_\_ SPEC. SECTIONS: \_\_\_\_\_ PAGE: \_\_\_\_\_

**REQUEST:**

Submitted By: Brandywine Contractors, Inc. Date: 02 January 2020

- 1.) Contract #22 – Special Systems scope bullet #4 indicates for the electrical contractor to install owner furnished projectors and mounts. Contract #6 - Carpentry & General Works bullet #35 indicate to install owner furnished smart TV's/displays, projectors, and mounts. Please confirm who is both installing smart TV's and projector/mounts.

---

**RESPONSE:**

- 1.) The Electrical Contractor (contract A-22) shall install the owner furnished projector(s) and mounts associated with the cafetorium audio/visual system. Owner furnished Smart TV's and mounts will be installed by the Carpentry and General Trades Contractor (contract A-06).

Response By: J.D. Bartlett, EDiS Company Date: 03 January 2020

---

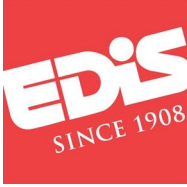

REQUEST FOR INFORMATION  
BID PACK A

TO: EDiS COMPANY PRE-BID RFI#: 062  
FROM: J.D. BARTLETT, EDiS COMPANY DATE: 02 JANUARY 2020  
PROJECT: SILVER LAKE ELEMENTARY SCHOOL – ADDITIONS & RENOVATIONS  
DWG. # / DETAIL: \_\_\_\_\_ SPEC. SECTIONS: \_\_\_\_\_ PAGE: \_\_\_\_\_

**REQUEST:**

Submitted By: Modular Concepts Date: 02 January 2020

- 1.) Advise what bid package owns the metal doors under the stage.

---

**RESPONSE:**

- 1.) Contract A-06 Carpentry and General Work.

Response By: J.D. Bartlett, EDiS Company Date: 03 January 2020

---

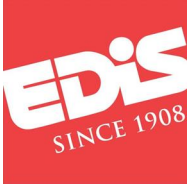

REQUEST FOR INFORMATION  
BID PACK A

TO: EDiS COMPANY PRE-BID RFI#: 063  
FROM: J.D. BARTLETT, EDiS COMPANY DATE: 02 JANUARY 2020  
PROJECT: SILVER LAKE ELEMENTARY SCHOOL – ADDITIONS & RENOVATIONS  
DWG. # / DETAIL: A41.2 / 3 SPEC. SECTIONS: \_\_\_\_\_ PAGE: \_\_\_\_\_

**REQUEST:**

Submitted By: Modular Concepts Date: 02 January 2020

- 1.) The front nosing at the stage is integral to the flooring system. The same nosing/flooring system should extend out to the edges of the wing walls (3/A41.2) at the treads and risers so there is no difference in material/finish. Verify this is part of the A-06 package and not A-10.

---

**RESPONSE:**

- 1.) See attached sketch. Refer to Addendum #2 for detailed revisions clarifying the responsibilities as it relates to the stage.

Response By: J.D. Bartlett, EDiS Company Date: 03 January 2020

---



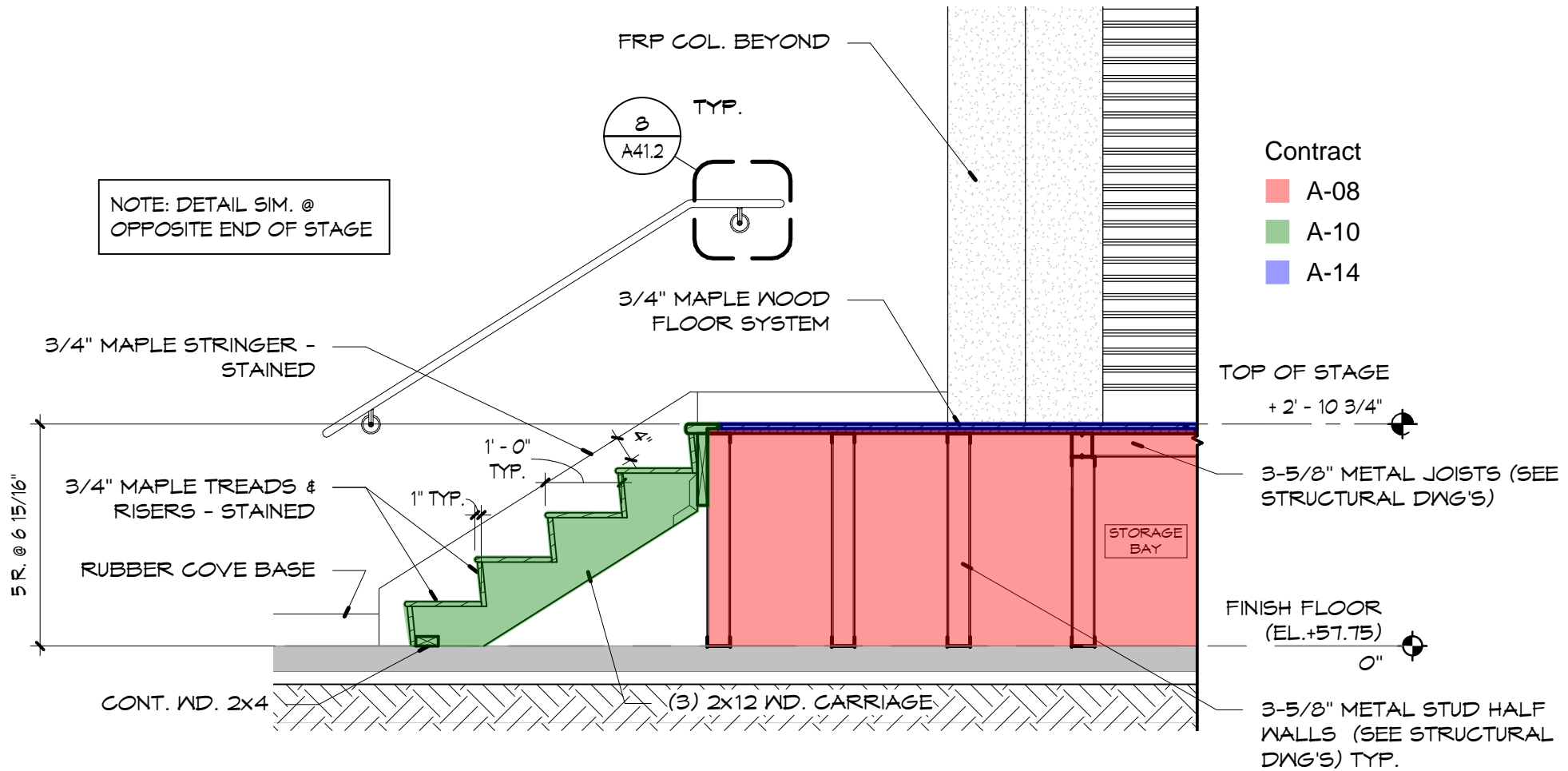

2

SECTION @ STAGE STAIR

1/2" = 1'-0"

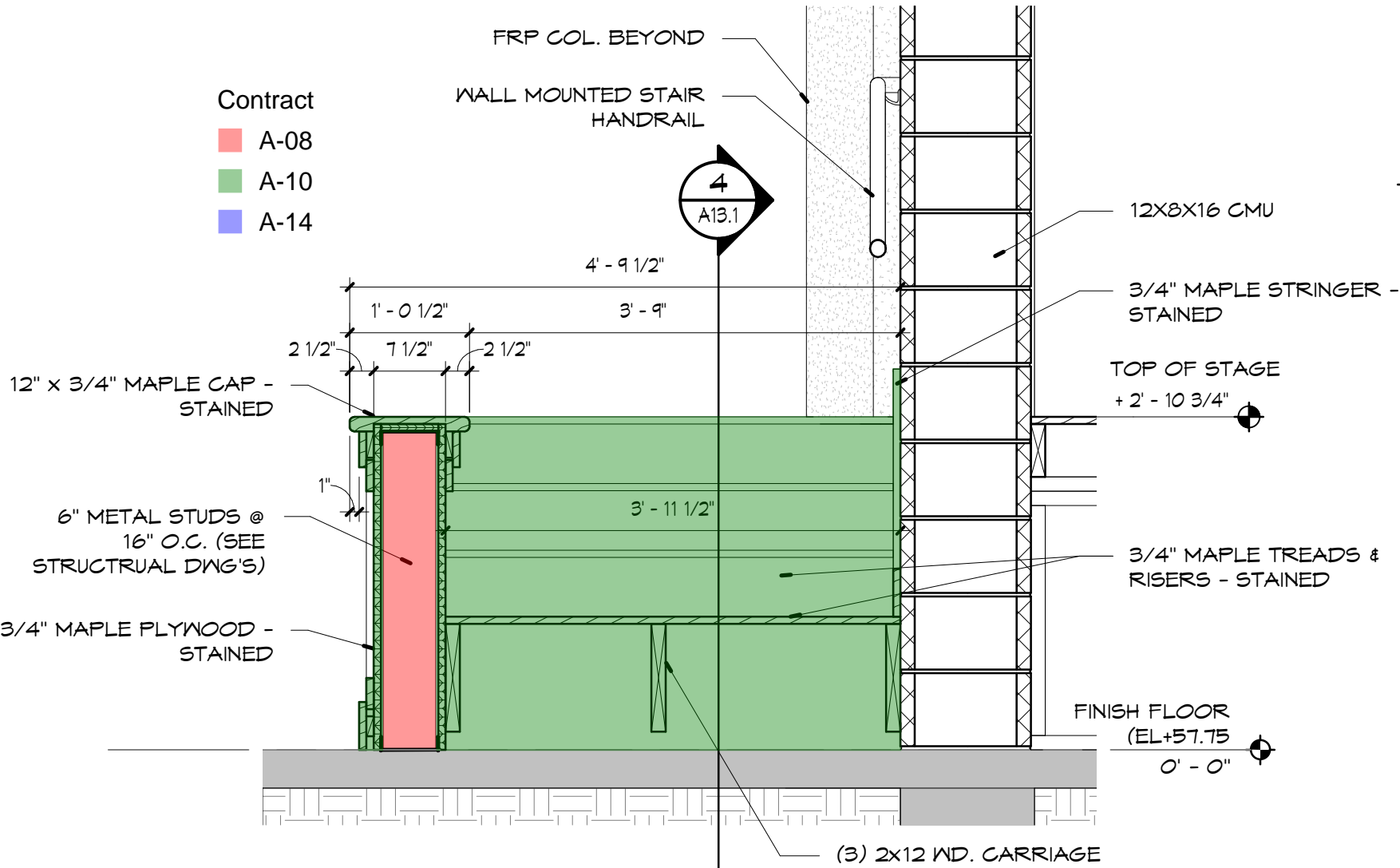

**3**

**SECTION @ STAGE STAIR**

3/4" = 1'-0"

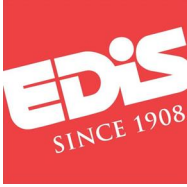

REQUEST FOR INFORMATION  
BID PACK A

TO: EDiS COMPANY PRE-BID RFI#: 064  
FROM: J.D. BARTLETT, EDiS COMPANY DATE: 02 JANUARY 2020  
PROJECT: SILVER LAKE ELEMENTARY SCHOOL – ADDITIONS & RENOVATIONS  
DWG. # / DETAIL: \_\_\_\_\_ SPEC. SECTIONS: \_\_\_\_\_ PAGE: \_\_\_\_\_

**REQUEST:**

Submitted By: Modular Concepts Date: 02 January 2020

- 1.) Specific scope for A-10 lists proscenium opening. Verify A-10 does not own the FRP column covers at each end of the stage.

---

---

**RESPONSE:**

- 1.) FRP column covers will be provided by contract A-08 - Metal Studs and Drywall.

Response By: J.D. Bartlett, EDiS Company Date: 03 January 2020

---

---

**Contract: A-07: Roofing**

**BID FORM**

For Bids Due: January 14, 2020 To: Appoquinimink School District  
118 South Sixth Street  
Odessa, DE 19730

Name of Bidder: \_\_\_\_\_

Bidder Address: \_\_\_\_\_  
\_\_\_\_\_

Contact Name: \_\_\_\_\_ E-Mail Address: \_\_\_\_\_

Delaware Business License No.: \_\_\_\_\_ Taxpayer ID No.: \_\_\_\_\_

(Other License Nos.): \_\_\_\_\_

**(A copy of Bidder's Delaware Business License must be attached to this form.)**

Phone No.: ( ) \_\_\_\_\_ - \_\_\_\_\_ Fax No.: ( ) \_\_\_\_\_ - \_\_\_\_\_

The undersigned, representing that he has read and understands the Bidding Documents and that this bid is made in accordance therewith, that he has visited the site and has familiarized himself with the local conditions under which the Work is to be performed, and that his bid is based upon the materials, systems and equipment described in the Bidding Documents without exception, hereby proposes and agrees to provide all labor, materials, plant, equipment, supplies, transport and other facilities required to execute the work described by the aforesaid documents for the lump sum itemized below:

\$ \_\_\_\_\_ (\$ \_\_\_\_\_)

**ALTERNATES**

Alternate prices conform to applicable project specification section. Refer to specifications for a complete description of the following Alternates. An "ADD" or "DEDUCT" amount is indicated by the crossed out part that does not apply.

**Alternate No. 1: Increase the Size of the Gymnasium**

Add/Deduct \_\_\_\_\_ (\$ \_\_\_\_\_)

**Alternate No. 12: Provide Lightning Protection System (BP1 ADDENDUM NO. 2)**

Add/Deduct \_\_\_\_\_ (\$ \_\_\_\_\_)

**Appoquinimink School District  
Silver Lake Elementary School Additions & Renovations**

Bid Package A

December 6, 2019  
**Addendum #2 – 03 JAN 2020**

---

I/We acknowledge Addendums numbered \_\_\_\_\_ and the price(s) submitted include any cost/schedule impact they may have.

This bid shall remain valid and cannot be withdrawn for sixty (60) days from the date of opening of bids, and the undersigned shall abide by the Bid Security forfeiture provisions. Bid Security is attached to this Bid.

The Owner shall have the right to reject any or all bids, and to waive any informality or irregularity in any bid received.

This bid is based upon work being accomplished by the Sub-Contractors named on the list attached to this bid.

The undersigned represents and warrants that he has complied and shall comply with all requirements of local, state, and national laws; that no legal requirement has been or shall be violated in making or accepting this bid, in awarding the contract to him or in the prosecution of the work required; that the bid is legal and firm; that he has not, directly or indirectly, entered into any agreement, participated in any collusion, or otherwise taken action in restraint of free competitive bidding.

Upon receipt of written notice of the acceptance of this Bid, the Bidder shall, within twenty (20) calendar days, execute the agreement in the required form and deliver the Contract Bonds, and Insurance Certificates, required by the Contract Documents.

I am / We are an Individual / a Partnership / a Corporation

By \_\_\_\_\_ Trading as \_\_\_\_\_  
(Individual's / General Partner's / Corporate Name)

\_\_\_\_\_  
(State of Corporation)

Business Address: \_\_\_\_\_  
\_\_\_\_\_  
\_\_\_\_\_  
\_\_\_\_\_

Witness: \_\_\_\_\_ By: \_\_\_\_\_  
(SEAL) ( Authorized Signature )

\_\_\_\_\_  
( Title )

Date: \_\_\_\_\_

ATTACHMENTS

Sub-Contractor List

Non-Collusion Statement  
Bid Bond  
Consent of Surety  
Affidavit of Employee Drug Testing Program  
Delaware Business License  
Town of Middletown Contractor's License  
(Others as Required by Project Manuals)

SUBCONTRACTOR LIST

In accordance with Title 29, Chapter 6962 (d)(10)b Delaware Code, the following sub-contractor listing must accompany the bid submittal. The name and address of the sub-contractor must be listed for each category where the bidder intends to use a sub-contractor to perform that category of work. In order to provide full disclosure and acceptance of the bid by the Owner, **it is required that bidders list themselves as being the sub-contractor for all categories where he/she is qualified and intends to perform such work.**

<u>Subcontractor</u> <u>Category</u>	<u>Subcontractor</u>	<u>Address (City &amp; State)</u>	<u>Subcontractors tax payer ID #</u> <u>or Delaware Business license #</u>
1. EPDM Membrane Roof System	_____	_____	_____
2. Asphalt Shingle Roof System	_____	_____	_____

NON-COLLUSION STATEMENT

This is to certify that the undersigned bidder has neither directly nor indirectly, entered into any agreement, participated in any collusion or otherwise taken any action in restraint of free competitive bidding in connection with this proposal submitted this date January 14, 2020.

All the terms and conditions of **Contract: A-07: Roofing** have been thoroughly examined and are understood.

NAME OF BIDDER: \_\_\_\_\_

AUTHORIZED REPRESENTATIVE  
(TYPED): \_\_\_\_\_

AUTHORIZED REPRESENTATIVE  
(SIGNATURE): \_\_\_\_\_

TITLE: \_\_\_\_\_

ADDRESS OF BIDDER: \_\_\_\_\_  
\_\_\_\_\_  
\_\_\_\_\_

PHONE NUMBER: \_\_\_\_\_

Sworn to and Subscribed before me this \_\_\_\_\_ day of \_\_\_\_\_ 20\_\_\_\_\_.

My Commission expires \_\_\_\_\_ NOTARY PUBLIC \_\_\_\_\_.

THIS PAGE MUST BE SIGNED AND NOTARIZED FOR YOUR BID TO BE CONSIDERED.



**BID BOND**

TO ACCOMPANY PROPOSAL  
(Not necessary if security is used)

KNOW ALL MEN BY THESE PRESENTS That: \_\_\_\_\_ of  
\_\_\_\_\_ in the County of \_\_\_\_\_ and State of \_\_\_\_\_ as  
Principal, and \_\_\_\_\_ of \_\_\_\_\_ in the County of \_\_\_\_\_  
\_\_\_\_\_ and State of \_\_\_\_\_ as Surety, legally authorized to do business in the State of Delaware  
("State"), are held and firmly unto the **Appoquinimink School District** in the sum of \_\_\_\_\_  
Dollars (\$ \_\_\_\_\_), or percent not to exceed \_\_\_\_\_  
\_\_\_\_\_ Dollars (\$ \_\_\_\_\_) of amount of bid on Contract No. \_\_\_\_\_ to be paid to the  
**Appoquinimink School District** for the use and benefit of the **Appoquinimink School District** for which payment well  
and truly to be made, we do bind ourselves, our and each of our heirs, executors, administrators, and successors, jointly  
and severally for and in the whole firmly by these presents.

NOW THE CONDITION OF THIS OBLIGATION IS SUCH That if the above bounden Principal who has submitted to the  
**Appoquinimink School District** a certain proposal to enter into this contract for the furnishing of certain material and/or  
services within the State, shall be awarded this Contract, and if said Principal shall well and truly enter into and execute  
this Contract as may be required by the terms of this Contract and approved by the **Appoquinimink School District** this  
Contract to be entered into within twenty days after the date of official notice of the award thereof in accordance with the  
terms of said proposal, then this obligation shall be void or else to be and remain in full force and virtue.

Sealed with \_\_\_\_\_ seal and dated this \_\_\_\_ day of \_\_\_\_\_ in the year of our Lord two thousand  
and \_\_\_\_\_ (20\_\_).

SEALED, AND DELIVERED IN THE PRESENCE OF

\_\_\_\_\_  
Name of Bidder (Organization)

Corporate Seal	By: _____
Attest _____	Authorized Signature
	_____
	Title
	_____
	Name of Surety
Witness _____	_____
	_____
	Title

---

CONSENT OF SURETY

DATE \_\_\_\_\_

To: **Appoquinimink School District**  
**118 South Sixth Street**  
**Odessa, DE 19730**

Gentlemen:

We, the \_\_\_\_\_

---

(Surety Company's Address)

---

a Surety Company authorized to do business in the State of Delaware hereby agrees that if

---

(Contractor)

---

(Address)

---

is awarded the Contract No. \_\_\_\_\_

We will write the required Performance and/or Labor and Material Bond required by Paragraph 9 of the Instructions to Bidders.

---

(Surety Company)

By \_\_\_\_\_  
(Attorney-in-Fact)

**AFFIDAVIT**  
**OF**  
**EMPLOYEE DRUG TESTING PROGRAM**

4104 Regulations for the Drug Testing of Contractor and Subcontractor Employees Working on Large Public Works Projects requires that Contractors and Subcontractors implement a program of mandatory drug testing for Employees who work on Large Public Works Contracts funded all or in part with public funds.

We hereby certify that we have in place or will implement during the entire term of the contract a Mandatory Drug Testing Program for our employees on the jobsite, including subcontractors that complies with this regulation:

**Contractor/Subcontractor Name:** \_\_\_\_\_

**Contractor/Subcontractor Address:** \_\_\_\_\_  
\_\_\_\_\_  
\_\_\_\_\_

**Authorized Representative (typed or printed):** \_\_\_\_\_

**Authorized Representative (signature):** \_\_\_\_\_

**Title:** \_\_\_\_\_

Sworn to and Subscribed before me this \_\_\_\_\_ day of \_\_\_\_\_ 20\_\_\_\_\_.

My Commission expires \_\_\_\_\_ NOTARY PUBLIC \_\_\_\_\_.

**THIS PAGE MUST BE SIGNED AND NOTARIZED FOR YOUR BID TO BE CONSIDERED.**

Contract: A-21: Electrical

BID FORM

For Bids Due: January 14, 2020 To: Appoquinimink School District  
118 South Sixth Street  
Odessa, DE 19730

Name of Bidder: \_\_\_\_\_

Bidder Address: \_\_\_\_\_  
\_\_\_\_\_

Contact Name: \_\_\_\_\_ E-Mail Address: \_\_\_\_\_

Delaware Business License No.: \_\_\_\_\_ Taxpayer ID No.: \_\_\_\_\_

(Other License Nos.): \_\_\_\_\_

**(A copy of Bidder's Delaware Business License must be attached to this form.)**

Phone No.: ( ) \_\_\_\_\_ - \_\_\_\_\_ Fax No.: ( ) \_\_\_\_\_ - \_\_\_\_\_

The undersigned, representing that he has read and understands the Bidding Documents and that this bid is made in accordance therewith, that he has visited the site and has familiarized himself with the local conditions under which the Work is to be performed, and that his bid is based upon the materials, systems and equipment described in the Bidding Documents without exception, hereby proposes and agrees to provide all labor, materials, plant, equipment, supplies, transport and other facilities required to execute the work described by the aforesaid documents for the lump sum itemized below:

\$ \_\_\_\_\_ (\$ \_\_\_\_\_)

ALTERNATES

Alternate prices conform to applicable project specification section. Refer to specifications for a complete description of the following Alternates. An "ADD" or "DEDUCT" amount is indicated by the crossed out part that does not apply.

Alternate No. 1: Increase the Size of the Gymnasium

Add/Deduct \_\_\_\_\_ (\$ \_\_\_\_\_)

~~Alternate No. 5a: Change Gymnasium Floor to Wood (Alt. No. 1 – Base Bid)~~

~~Add/Deduct \_\_\_\_\_ (\$ \_\_\_\_\_)~~

Appoquinimink School District  
Silver Lake Elementary School Additions & Renovations  
Bid Package A

December 6, 2019  
Addendum #2 – 03 JAN 2020

~~Alternate No. 5b: Change Gymnasium Floor to Wood (Alt. No. 1 – Alternate) (BP1 ADDENDUM NO. 2)~~

Add/Deduct \_\_\_\_\_ (\$ \_\_\_\_\_)

Alternate No. 7: Add Decorative Ceilings in Common Areas

Add/Deduct \_\_\_\_\_ (\$ \_\_\_\_\_)

~~Alternate No. 8: Add Outdoor Classroom in the Courtyard (BP1 ADDENDUM NO. 2)~~

Add/Deduct \_\_\_\_\_ (\$ \_\_\_\_\_)

~~Alternate No. 9: Courtyard Landscaping (BP1 ADDENDUM NO. 2)~~

Add/Deduct \_\_\_\_\_ (\$ \_\_\_\_\_)

**Alternate No. 12: Provide Lightning Protection System (BP1 ADDENDUM NO. 2)**

Add/Deduct \_\_\_\_\_ (\$ \_\_\_\_\_)

I/We acknowledge Addendums numbered \_\_\_\_\_ and the price(s) submitted include any cost/schedule impact they may have.

This bid shall remain valid and cannot be withdrawn for sixty (60) days from the date of opening of bids, and the undersigned shall abide by the Bid Security forfeiture provisions. Bid Security is attached to this Bid.

The Owner shall have the right to reject any or all bids, and to waive any informality or irregularity in any bid received.

This bid is based upon work being accomplished by the Sub-Contractors named on the list attached to this bid.

The undersigned represents and warrants that he has complied and shall comply with all requirements of local, state, and national laws; that no legal requirement has been or shall be violated in making or accepting this bid, in awarding the contract to him or in the prosecution of the work required; that the bid is legal and firm; that he has not, directly or indirectly, entered into any agreement, participated in any collusion, or otherwise taken action in restraint of free competitive bidding.

Upon receipt of written notice of the acceptance of this Bid, the Bidder shall, within twenty (20) calendar days, execute the agreement in the required form and deliver the Contract Bonds, and Insurance Certificates, required by the Contract Documents.

I am / We are an Individual / a Partnership / a Corporation

By \_\_\_\_\_ Trading as \_\_\_\_\_  
(Individual's / General Partner's / Corporate Name)

---

(State of Corporation)

Business Address: \_\_\_\_\_  
\_\_\_\_\_  
\_\_\_\_\_  
\_\_\_\_\_

Witness: \_\_\_\_\_ By: \_\_\_\_\_  
( Authorized Signature )

(SEAL)

\_\_\_\_\_

( Title )

Date: \_\_\_\_\_

ATTACHMENTS

- Sub-Contractor List
- Non-Collusion Statement
- Bid Bond
- Consent of Surety
- Affidavit of Employee Drug Testing Program
- Delaware Business License
- Town of Middletown Contractor's License
- (Others as Required by Project Manuals)

SUBCONTRACTOR LIST

In accordance with Title 29, Chapter 6962 (d)(10)b Delaware Code, the following sub-contractor listing must accompany the bid submittal. The name and address of the sub-contractor must be listed for each category where the bidder intends to use a sub-contractor to perform that category of work. In order to provide full disclosure and acceptance of the bid by the Owner, **it is required that bidders list themselves as being the sub-contractor for all categories where he/she is qualified and intends to perform such work.**

<u>Subcontractor Category</u>	<u>Subcontractor</u>	<u>Address (City &amp; State)</u>	<u>Subcontractors tax payer ID # or Delaware Business license #</u>
1. Electrical	_____	_____	_____
2. Caulking	_____	_____	_____

NON-COLLUSION STATEMENT

This is to certify that the undersigned bidder has neither directly nor indirectly, entered into any agreement, participated in any collusion or otherwise taken any action in restraint of free competitive bidding in connection with this proposal submitted this date January 14, 2020.

All the terms and conditions of **Contract: A-21: Electrical** have been thoroughly examined and are understood.

NAME OF BIDDER: \_\_\_\_\_

AUTHORIZED REPRESENTATIVE  
(TYPED): \_\_\_\_\_

AUTHORIZED REPRESENTATIVE  
(SIGNATURE): \_\_\_\_\_

TITLE: \_\_\_\_\_

ADDRESS OF BIDDER: \_\_\_\_\_  
\_\_\_\_\_  
\_\_\_\_\_

PHONE NUMBER: \_\_\_\_\_

Sworn to and Subscribed before me this \_\_\_\_\_ day of \_\_\_\_\_ 20\_\_\_\_\_.

My Commission expires \_\_\_\_\_ NOTARY PUBLIC \_\_\_\_\_.

THIS PAGE MUST BE SIGNED AND NOTARIZED FOR YOUR BID TO BE CONSIDERED.



**BID BOND**

TO ACCOMPANY PROPOSAL  
(Not necessary if security is used)

KNOW ALL MEN BY THESE PRESENTS That: \_\_\_\_\_ of  
\_\_\_\_\_ in the County of \_\_\_\_\_ and State of \_\_\_\_\_ as  
Principal, and \_\_\_\_\_ of \_\_\_\_\_ in the County of \_\_\_\_\_  
\_\_\_\_\_ and State of \_\_\_\_\_ as Surety, legally authorized to do business in the State of Delaware  
("State"), are held and firmly unto the **Appoquinimink School District** in the sum of \_\_\_\_\_  
Dollars (\$ \_\_\_\_\_), or percent not to exceed \_\_\_\_\_  
\_\_\_\_\_ Dollars (\$ \_\_\_\_\_) of amount of bid on Contract No. \_\_\_\_\_ to be paid to the  
**Appoquinimink School District** for the use and benefit of the **Appoquinimink School District** for which payment well  
and truly to be made, we do bind ourselves, our and each of our heirs, executors, administrators, and successors, jointly  
and severally for and in the whole firmly by these presents.

NOW THE CONDITION OF THIS OBLIGATION IS SUCH That if the above bounden Principal who has submitted to the  
**Appoquinimink School District** a certain proposal to enter into this contract for the furnishing of certain material and/or  
services within the State, shall be awarded this Contract, and if said Principal shall well and truly enter into and execute  
this Contract as may be required by the terms of this Contract and approved by the **Appoquinimink School District** this  
Contract to be entered into within twenty days after the date of official notice of the award thereof in accordance with the  
terms of said proposal, then this obligation shall be void or else to be and remain in full force and virtue.

Sealed with \_\_\_\_\_ seal and dated this \_\_\_\_ day of \_\_\_\_\_ in the year of our Lord two thousand  
and \_\_\_\_\_ (20\_\_).

SEALED, AND DELIVERED IN THE PRESENCE OF

\_\_\_\_\_  
Name of Bidder (Organization)

Corporate Seal	By: _____ Authorized Signature
Attest _____	_____ Title
Witness _____	_____ Name of Surety
	_____ Title

---

CONSENT OF SURETY

DATE \_\_\_\_\_

To: **Appoquinimink School District**  
**118 South Sixth Street**  
**Odessa, DE 19730**

Gentlemen:

We, the \_\_\_\_\_

---

(Surety Company's Address)

---

a Surety Company authorized to do business in the State of Delaware hereby agrees that if

---

(Contractor)

---

(Address)

---

is awarded the Contract No. \_\_\_\_\_

We will write the required Performance and/or Labor and Material Bond required by Paragraph 9 of the Instructions to Bidders.

---

(Surety Company)

By \_\_\_\_\_  
(Attorney-in-Fact)

**AFFIDAVIT**  
**OF**  
**EMPLOYEE DRUG TESTING PROGRAM**

4104 Regulations for the Drug Testing of Contractor and Subcontractor Employees Working on Large Public Works Projects requires that Contractors and Subcontractors implement a program of mandatory drug testing for Employees who work on Large Public Works Contracts funded all or in part with public funds.

We hereby certify that we have in place or will implement during the entire term of the contract a Mandatory Drug Testing Program for our employees on the jobsite, including subcontractors that complies with this regulation:

**Contractor/Subcontractor Name:** \_\_\_\_\_

**Contractor/Subcontractor Address:** \_\_\_\_\_  
\_\_\_\_\_  
\_\_\_\_\_

**Authorized Representative (typed or printed):** \_\_\_\_\_

**Authorized Representative (signature):** \_\_\_\_\_

**Title:** \_\_\_\_\_

Sworn to and Subscribed before me this \_\_\_\_\_ day of \_\_\_\_\_ 20\_\_\_\_\_.

My Commission expires \_\_\_\_\_ NOTARY PUBLIC \_\_\_\_\_.

**THIS PAGE MUST BE SIGNED AND NOTARIZED FOR YOUR BID TO BE CONSIDERED.**

Contract: A-25: Telephone System

BID FORM

For Bids Due: January 14, 2020 To: Appoquinimink School District  
118 South Sixth Street  
Odessa, DE 19730

Name of Bidder: \_\_\_\_\_

Bidder Address: \_\_\_\_\_  
\_\_\_\_\_

Contact Name: \_\_\_\_\_ E-Mail Address: \_\_\_\_\_

Delaware Business License No.: \_\_\_\_\_ Taxpayer ID No.: \_\_\_\_\_

(Other License Nos.): \_\_\_\_\_

**(A copy of Bidder's Delaware Business License must be attached to this form.)**

Phone No.: ( ) \_\_\_\_\_ - \_\_\_\_\_ Fax No.: ( ) \_\_\_\_\_ - \_\_\_\_\_

The undersigned, representing that he has read and understands the Bidding Documents and that this bid is made in accordance therewith, that he has visited the site and has familiarized himself with the local conditions under which the Work is to be performed, and that his bid is based upon the materials, systems and equipment described in the Bidding Documents without exception, hereby proposes and agrees to provide all labor, materials, plant, equipment, supplies, transport and other facilities required to execute the work described by the aforesaid documents for the lump sum itemized below:

\$ \_\_\_\_\_ (\$ \_\_\_\_\_)

I/We acknowledge Addendums numbered \_\_\_\_\_ and the price(s) submitted include any cost/schedule impact they may have.

This bid shall remain valid and cannot be withdrawn for sixty (60) days from the date of opening of bids, and the undersigned shall abide by the Bid Security forfeiture provisions. Bid Security is attached to this Bid.

The Owner shall have the right to reject any or all bids, and to waive any informality or irregularity in any bid received.

This bid is based upon work being accomplished by the Sub-Contractors named on the list attached to this bid.

The undersigned represents and warrants that he has complied and shall comply with all requirements of local, state, and national laws; that no legal requirement has been or shall be violated in making or accepting this bid, in awarding the

**Appoquinimink School District  
Silver Lake Elementary School Additions & Renovations**

Bid Package A

December 6, 2019

**Addendum #2 – 03 JAN 2020**

contract to him or in the prosecution of the work required; that the bid is legal and firm; that he has not, directly or indirectly, entered into any agreement, participated in any collusion, or otherwise taken action in restraint of free competitive bidding.

Upon receipt of written notice of the acceptance of this Bid, the Bidder shall, within twenty (20) calendar days, execute the agreement in the required form and deliver the Contract Bonds, and Insurance Certificates, required by the Contract Documents.

I am / We are an Individual / a Partnership / a Corporation

By \_\_\_\_\_ Trading as \_\_\_\_\_  
(Individual's / General Partner's / Corporate Name)

\_\_\_\_\_  
(State of Corporation)

Business Address: \_\_\_\_\_  
\_\_\_\_\_  
\_\_\_\_\_  
\_\_\_\_\_

Witness: \_\_\_\_\_ By: \_\_\_\_\_  
(SEAL) ( Authorized Signature )

\_\_\_\_\_  
( Title )

Date: \_\_\_\_\_

ATTACHMENTS

- Sub-Contractor List
- Non-Collusion Statement
- Bid Bond
- Consent of Surety
- Affidavit of Employee Drug Testing Program
- Delaware Business License
- Town of Middletown Contractor's License
- (Others as Required by Project Manuals)

---

SUBCONTRACTOR LIST

In accordance with Title 29, Chapter 6962 (d)(10)b Delaware Code, the following sub-contractor listing must accompany the bid submittal. The name and address of the sub-contractor must be listed for each category where the bidder intends to use a sub-contractor to perform that category of work. In order to provide full disclosure and acceptance of the bid by the Owner, **it is required that bidders list themselves as being the sub-contractor for all categories where he/she is qualified and intends to perform such work.**

<u>Subcontractor</u> <u>Category</u>	<u>Subcontractor</u>	<u>Address (City &amp; State)</u>	<u>Subcontractors tax payer ID #</u> <u>or Delaware Business license #</u>
1. Telephone Systems	_____	_____	_____

NON-COLLUSION STATEMENT

This is to certify that the undersigned bidder has neither directly nor indirectly, entered into any agreement, participated in any collusion or otherwise taken any action in restraint of free competitive bidding in connection with this proposal submitted this date January 14, 2020.

All the terms and conditions of **Contract: A-25: Telephone System** have been thoroughly examined and are understood.

NAME OF BIDDER: \_\_\_\_\_

AUTHORIZED REPRESENTATIVE  
(TYPED): \_\_\_\_\_

AUTHORIZED REPRESENTATIVE  
(SIGNATURE): \_\_\_\_\_

TITLE: \_\_\_\_\_

ADDRESS OF BIDDER: \_\_\_\_\_  
\_\_\_\_\_  
\_\_\_\_\_

PHONE NUMBER: \_\_\_\_\_

Sworn to and Subscribed before me this \_\_\_\_\_ day of \_\_\_\_\_ 20\_\_\_\_.

My Commission expires \_\_\_\_\_. NOTARY PUBLIC \_\_\_\_\_.

THIS PAGE MUST BE SIGNED AND NOTARIZED FOR YOUR BID TO BE CONSIDERED.

**BID BOND**

TO ACCOMPANY PROPOSAL  
(Not necessary if security is used)

KNOW ALL MEN BY THESE PRESENTS That: \_\_\_\_\_ of  
\_\_\_\_\_ in the County of \_\_\_\_\_ and State of \_\_\_\_\_ as  
Principal, and \_\_\_\_\_ of \_\_\_\_\_ in the County of \_\_\_\_\_  
\_\_\_\_\_ and State of \_\_\_\_\_ as Surety, legally authorized to do business in the State of Delaware  
("State"), are held and firmly unto the **Appoquinimink School District** in the sum of \_\_\_\_\_  
Dollars (\$ \_\_\_\_\_), or percent not to exceed \_\_\_\_\_  
\_\_\_\_\_ Dollars (\$ \_\_\_\_\_) of amount of bid on Contract No. \_\_\_\_\_ to be paid to the  
**Appoquinimink School District** for the use and benefit of the **Appoquinimink School District** for which payment well  
and truly to be made, we do bind ourselves, our and each of our heirs, executors, administrators, and successors, jointly  
and severally for and in the whole firmly by these presents.

NOW THE CONDITION OF THIS OBLIGATION IS SUCH That if the above bounden Principal who has submitted to the  
**Appoquinimink School District** a certain proposal to enter into this contract for the furnishing of certain material and/or  
services within the State, shall be awarded this Contract, and if said Principal shall well and truly enter into and execute  
this Contract as may be required by the terms of this Contract and approved by the **Appoquinimink School District** this  
Contract to be entered into within twenty days after the date of official notice of the award thereof in accordance with the  
terms of said proposal, then this obligation shall be void or else to be and remain in full force and virtue.

Sealed with \_\_\_\_\_ seal and dated this \_\_\_\_ day of \_\_\_\_\_ in the year of our Lord two thousand  
and \_\_\_\_\_ (20\_\_).

SEALED, AND DELIVERED IN THE PRESENCE OF

\_\_\_\_\_  
Name of Bidder (Organization)

Corporate Seal	By: _____ Authorized Signature
Attest _____	_____ Title
Witness _____	_____ Name of Surety
	_____ Title



---

CONSENT OF SURETY

DATE \_\_\_\_\_

To: **Appoquinimink School District**  
**118 South Sixth Street**  
**Odessa, DE 19730**

Gentlemen:

We, the \_\_\_\_\_

---

(Surety Company's Address)

---

a Surety Company authorized to do business in the State of Delaware hereby agrees that if

---

(Contractor)

---

(Address)

---

is awarded the Contract No. \_\_\_\_\_

We will write the required Performance and/or Labor and Material Bond required by Paragraph 9 of the Instructions to Bidders.

---

(Surety Company)

By \_\_\_\_\_  
(Attorney-in-Fact)

**AFFIDAVIT**  
**OF**  
**EMPLOYEE DRUG TESTING PROGRAM**

4104 Regulations for the Drug Testing of Contractor and Subcontractor Employees Working on Large Public Works Projects requires that Contractors and Subcontractors implement a program of mandatory drug testing for Employees who work on Large Public Works Contracts funded all or in part with public funds.

We hereby certify that we have in place or will implement during the entire term of the contract a Mandatory Drug Testing Program for our employees on the jobsite, including subcontractors that complies with this regulation:

**Contractor/Subcontractor Name:** \_\_\_\_\_

**Contractor/Subcontractor Address:** \_\_\_\_\_  
\_\_\_\_\_  
\_\_\_\_\_

**Authorized Representative (typed or printed):** \_\_\_\_\_

**Authorized Representative (signature):** \_\_\_\_\_

**Title:** \_\_\_\_\_

Sworn to and Subscribed before me this \_\_\_\_\_ day of \_\_\_\_\_ 20\_\_\_\_\_.

My Commission expires \_\_\_\_\_ . NOTARY PUBLIC \_\_\_\_\_ .

**THIS PAGE MUST BE SIGNED AND NOTARIZED FOR YOUR BID TO BE CONSIDERED.**

END OF SECTION

SECTION 011100 - SUMMARY OF WORK1. RELATED DOCUMENTS

- A. Drawings and general provisions of the Contract, including General and Supplementary Conditions and other Division 1 Sections, apply to work of this Section.

2. CONTRACTS

- A. The work will be performed under separate prime contracts managed by the Construction Manager.

3. ALTERATIONS & COORDINATION

- A. Contractor shall be responsible to coordinate their work with the work of others, including, but not limited to, the preparation of general coordination drawings, diagrams and schedules, and control of site utilization, from the beginning of activity, through project close-out and warranty periods.

4. KNOWLEDGE OF CONTRACT REQUIREMENTS

- A. The Contractor and his Subcontractors, Sub-subcontractors and material men shall consult in detail the Contract Documents for instructions and requirements pertaining to the Work, and at his and their cost, shall provide all labor, materials, equipment and services necessary to furnish, install and complete the work in strict conformance with all provisions thereof.
- B. The Contractor will be held to have examined the site of the Work prior to submitting his proposal and informed himself, his Subcontractors, Sub-subcontractors and material men of all existing conditions affecting the execution of the Work.
- C. The Contractor will be held to have examined the Contract Documents and modifications thereto, as they may affect subdivisions of the Work and informed himself, his Subcontractors, Sub-subcontractors and material men of all conditions thereof affecting the execution of the Work.
- D. The Scope of Work for the Contract is not necessarily limited to the description of each section of the Specifications and the illustrations shown on the Drawings. Include all minor items not expressly indicated in the Contract Documents, or as might be found necessary as a result of field conditions, in order to complete the Work as it is intended, without any gaps between the various subdivisions of work.
- E. The Contractor will be held to be thoroughly familiar with all conditions affecting labor in the area of the Project including, but not limited to, Unions, incentive pay, procurements, living, parking and commuting conditions and to have informed his Subcontractors and Sub-subcontractors thereof.

5. CONTRACT DOCUMENTS INFORMATION

- A. The Contract Documents are prepared in accordance with available information as to existing conditions and locations. If, during construction, conditions are revealed at variance with the Contract Documents, notify the Construction Manager immediately, but no more than three (3) days from the day the variance is first known. Failure to give timely notice shall operate to waive any claim Contractor might otherwise have for an adjustment to Contract Time or Sum as a consequence of such variance.
- B. The Specifications determine the kinds and methods of installation of the various materials, the Drawings establish the quantities, dimensions and details of materials, the schedules on the Drawings give the location, type and extent of the materials.
- C. Dimensions given on the Drawings govern scale measurements and large scale drawings govern small scale drawings, except as to anything omitted unless such omission is expressly noted on the large scale drawings.
- D. The techniques or methods of specifying to record requirements varies throughout text, and may include “prescriptive”, “open generic/descriptive”, “compliance with standards”, “performance”, “proprietary”, or a combination of these. The methods used for specifying one unit of work has no bearing on requirements for another unit of work.
- E. Whenever a material, article or piece of equipment is referred to in the singular number in the Contract Documents, it shall be the same as referring to it in the plural. As many such materials, articles or pieces of equipment shall be provided as are required to complete the Work.
- F. Whenever a material, article or piece of equipment is specified by reference to a governmental, trade association of similar standard, it shall comply with the requirements of the latest publication thereof and amendments thereto in effect on the bid date.
- G. In addition to the requirements of the Contract Documents, Contractor’s work shall also comply with applicable standards of the construction industry and those industry standards are made a part of Contract Documents by reference, as if copied directly into Contract Documents, or as if published copies were bound herein.
- H. Where compliance with two (2) or more industry standards, contract requirements, or sets of requirements is specified, and overlapping of those different standards or requirements establishes different or conflicting minimums or levels of quality, then the most stringent requirements, which are generally recognized to be also the most costly, is intended and will be enforced, unless specifically detailed language written into the Contract Documents clearly indicates that a less stringent requirement is to be fulfilled. Refer apparently equal but different requirements, and uncertainties as to which level of quality is more stringent, to Architect for decision before proceeding.

- I. Reference standards referenced directly in Contract Documents or by governing regulations have precedence over non-reference standards which are recognized in industry for applicability of work.
  - J. Contractor's bid is based on the complete set of Contract Documents including documents not specifically issued as part of the bid pack but referenced in same.
6. SCOPE OF WORK/GENERAL INFORMATION
- A. A Scope of Work for each contract to be awarded on the project follows in this section. When a Contract has been awarded to a Contractor, the successful Contractor will be listed after the title of the Contract. When no Contract has yet been awarded, no Contractor's name will be listed. Previous Scopes of Work include addendum changes.
  - B. Contractor is responsible for performing the work listed in the Summary of Work for his contract. Contractor is also responsible for knowing the work that has been assigned to preceding contracts. No additional compensation or extension of time will be allowed a Contractor due to his ignorance of the work assigned to his Contract or to other contracts which may affect his work. The Contractor is responsible, however, for all items which are covered in the Specifications and Drawings relating to their Contract if not specifically mentioned in the Summary of Work.
  - C. The Construction Manager will provide on-site a source for temporary electric, temporary water and portable sanitation facilities only. It is each Contractor's responsibility to make the necessary connections, including all material for temporary electric and water. Please note that utility charges for office trailers will be the responsibility of the individual Contractors.
  - D. A dumpster will be provided on site for free use by Contractors to dispose of non-hazardous, common, work-related refuse. Clean-up is the responsibility of each Contractor. Clean up shall be performed on a daily basis. Contractors not complying will be advised in writing and back charged for all costs associated with the cleanup of their work.
  - E. Contractors are reminded that there are limited storage areas available on site. Off-site storage will be the responsibility of each individual Contractor.
  - F. Office trailer permits off site will be the responsibility of each individual Contractor. On site Contractor's field offices, one (1) per Contractor, if required, will be located as directed by the Construction Manager. **Note: Site may be geographically limited on space and contractors will be permitted space for field offices on an as-needed basis. (BPA ADDENDUM NO. 2)**
  - G. Contractor will be prepared to discuss and submit a detailed project schedule seven (7) days after receipt of Notice to Proceed and to begin its submittal process. The Project

Schedule is an integral part of this contract. Certain construction sequences and priorities must take place in order to meet the target dates. Concentrated work periods will occur and each Contractor is responsible to staff the project as required by the current Construction Schedule or as directed by the Construction Manager. Contractor will cooperate with the Construction Manager in planning and meeting the required sequences of work and Project Schedule as periodically updated by the Construction Manager.

- H. All bids must include insurance limits in accordance with Article 11 of the Section 007300 SUPPLEMENTARY CONDITIONS.
- I. Hoisting, scaffolding and material handling is the responsibility of each Contractor, unless otherwise noted.
- J. Contractor will be responsible for layout of its own work. The Construction Manager will provide benchmark and layout of the building line.
- K. Contractor will be responsible to keep clean public roadways soiled by construction traffic on a daily basis. If cleaning is not done, the Construction Manager may perform the cleaning on an overtime basis and backcharge the Contractor responsible.
- L. Contractor Scopes of Work and Schedule are interrelated. Familiarity with each is required.
- M. The Construction Manager will provide testing services for soil, concrete, **masonry, grout, structural studs**, and steel. Other testing as required by the Contract Documents will be in accordance with the technical specifications and/or the individual scope of work. Refer to Specification Section ~~004500~~ **014500 - QUALITY CONTROL. (BPA ADDENDUM NO. 2)**
- N. Safety is the responsibility of each individual Contractor. The project will be governed under the guidelines of OSHA.
- O. Inter-Contractor shop drawing distribution will be performed by the Construction Manager. Contractor is individually responsible for either coordinating his work with these distributed drawings or notifying the Construction Manager, in writing, of any discrepancies.
- P. Coordination with other trades will be required. The Contractor will be required to attend periodic coordination meetings with other trades where requirements, conflicts and coordination issues will be discussed and resolved. Attendance when requested will be mandatory. If inter-Contractor coordination is not satisfactorily performed, the conflicting Contractors shall mutually share the cost to relocate and/or reinstall their work.
- Q. Contractor shall submit a schedule of values to the Construction Manager prior to the

submission of their first invoice for approval through Building Blok.

- R. Contractor is expected to review and coordinate its Work with the complete set of Contract Documents, including all items noted as by his trade whether or not shown on that particular set of drawings. Documents are available at the site for review.
- S. Contractor is responsible for obtaining all necessary permits required for his work, including street permits. Unless otherwise noted, building permit shall be secured by the Construction Manager. Any subcontractor who will be restricting access to street, right of way or adjacent property must notify the Construction Manager 48 hours in advance.
- T. Contractor's License: Submit a copy of all business licenses required by local and state agencies.
- U. Contractor shall absorb, without additional compensation, any and all costs of working beyond normal hours to maintain job progress in accordance with the current construction schedule.
- V. No asbestos or PCB's in or on any material or equipment will be accepted or allowed on this project. All hazardous materials will be treated in accordance with all State and Federal regulations.
- W. Daily cleanup of the work is the responsibility of each individual Contractor which includes broom cleaning of their debris as required. Contractor will be individually back charged by the Construction Manager for clean up not satisfactorily performed by the Contractor.
- X. In the event asbestos is uncovered, the Contractor shall notify the Construction Manager of the areas requiring removal of asbestos. The Construction Manager shall then coordinate the removal with the Owner.
- Y. This project is to be constructed adjacent to and in existing buildings. Contractor shall exercise all due precautions to minimize noise, air pollution and any other construction hazards which in any way would cause discomfort or danger to the occupants of the existing building in the area.
- Z. Existing mechanical, electrical, plumbing, sprinkler, medical gas, fire alarm, etc. systems will be shut off and locked out by the Owner as required by the Work. Tie-in's and modifications to those systems will be performed by the specific Contractor associated with the work as indicated in the Contract Documents. Re-energizing and re-startup of all systems should be performed by the Owner.
- AA. The Safety Cable System shall not be altered or removed without a written request submitted to the Project Manager with a copy to the Field Manager. It shall be the responsibility of each and every Contractor that is removing or altering the Safety Cable System to maintain the fall protection safety provided by the safety cable and not leave

the area unprotected. Each and every Contractor shall be responsible to re-install the Safety Cable System immediately after work is completed. Each and every Contractor shall be responsible to re-install the Safety Cable System in accordance to OSHA standards.

- AB. Normal work hours for this project are from 7:00 a.m. to 3:30 p.m. Any work to be performed outside of these hours must receive prior approval from the Construction Manager. Requests to work beyond normal work hours shall be submitted at least 48 hours prior.
- AC. Contractor is responsible for having a competent project superintendent/foreman on-site during all work performed under its contract.
- AD. In the event the Contractor has non-English speaking employees or subcontractors on the project, they shall have a superintendent or foreman on site, at all times, who speaks English and can communicate with Contractor's employees. Should the Contractor fail to meet this requirement, at any time, Construction Manager may direct all Work to stop until the proper supervision is on site. The Contractor will be responsible for maintaining the project work schedule and make up at its own expense, any delay to the Schedule resulting from the work stoppage.
- AE. Punch List Procedures: Contractor shall be given a copy of the punch list with his appropriate work identified. Contractor shall have nine (9) calendar work days to complete its punch list work. On the 10th day or as determined by the Construction Manager, the Construction Manager shall employ other contractors, as required, to complete any incomplete punch list work and retain from the appropriate Contractors retainage all costs incurred.
- AF. Contractor shall provide the necessary safety barricades and railings required to complete their work and comply with all OSHA, local code and contract specifications.
- AG. Prohibition of Using Photographs on EDis Projects: The Contractor and all associated subcontractors agrees to not issue any news release or advertising pertaining to the Work or the Project, including references to the Project on the Contractor's/subcontractor website or other social media outlets, without obtaining EDis' prior written approval, in each instance. The Contractor, for itself, its employees, vendors and subcontractors, agrees to not use the name of the Owner, the Project, EDis or any photographs, videos, or other images of the Project in connection with any of Contractor's business promotion activities, advertising, website, social media outlets, or operations, without EDis' prior written approval in each instance.
- AH. Each contractor shall must provide a silica exposure plan that meets or exceeds the new 2017 silica OSHA requirements. At a minimum, and it must be implemented in to the safety plan, including all monitoring, testing, limits exposure, provide respiratory plan and/or equipment modifications such as water and keep records of exposures.



- AI. It is strongly recommended that each prospective Bidder shall visit the site of the proposed work, fully acquaint and familiarize themselves with the conditions as they exist and the character of the operations to be carried out under the proposed Contract, and make such investigation as he may see fit so that he shall fully understand the facilities, physical conditions and restrictions affecting the work under the Contract. Claims for additional compensation and/or extensions of time because of Contractor's failure to familiarize himself with all conditions which might affect the work shall not be allowed.

CONTRACT NO. A-01 - DEMOLITION

A. Work included in this contract consists of, but is not necessarily limited to, all labor, materials and equipment for:

- Technical Specification Sections:

Division 0	Bidding and Contract Requirements
Division 1	General Requirements
Section 024119	Selective Structure Demolition

This contract also includes, but is not necessarily limited to, all labor, materials and equipment for the following:

1. Provide all labor, material, trucking, equipment, disposal, hoisting, scaffolding, power, temporary facilities, permit fees, supervision, layout, clean up, etc. for the complete performance of all demolition work, specifically demolition work within the building proper and as identified on Drawings AD.1, AD.A, AD.B, PD.A, PD.B, MD.A1, MD.A2, MD.B1, MD.B2, FD.A, FD.B, ED.A1, ED.A2, ED.B1, ED.B2 of the bid documents. **This Contractor is responsible for demolition of heating plant and cooling plant in their entirety, including equipment to be demolished in existing exterior mechanical yard.** Demolition and/or removal of all other items are the responsibility of the Sitework Contractor. Prior to demolition, Mechanical and Plumbing systems will be safed-off, disconnected and capped or plugged by the Mechanical & Plumbing Contractor and electrical circuits to equipment to be demolished will be safed-off and disconnected by the Electrical Contractor. **This Contractor shall notify all such authorities in advance and obtain their approval and cooperation in shutting off utilities.** This Contractor shall be responsible for all coordination as necessary to complete the scope of this contract. **(BPA ADDENDUM NO. 2)**
  
2. This Contractor shall visit the site of the proposed work, fully acquaint and familiarize himself with the conditions as they exist and the character of the operations to be carried out under the proposed Contract, and make such investigation as he may see fit so that he shall fully understand the facilities, physical conditions and restrictions affecting the work under the Contract. Claims for additional compensation and/or extensions of time because of Contractor's failure to familiarize himself with all conditions which might affect the work shall not be allowed.
  
3. This Contractor shall include all selective demolition and wrecking of the existing structures at the following location: **Silver Lake Elementary School, 200 East Cochran Street, Middletown, Delaware 19709.**
  
4. Perform selective demolition of structures and buildings and their appertains construction to new subgrade grade level. Fill in all depressions to new subgrade grade level including vaults and areaways beyond the face of the building. Fill must be clean common compactable fill or select material. Excess material to be removed from site in a legal

manner.

5. The Contractor will determine the sequence of demolition and where necessary provide temporary sheeting, shoring, or bracing necessary to ensure portions of the existing structure are to remain undisturbed. The sheeting, shoring, or bracing shall be designed by a professional engineer. The cost for these engineering services shall be paid by this Contractor.
6. Remove from site all combustible material including, but not limited to wood, steel, iron, structural steel, and dispose of in a legal manner. No on site burning of material will be allowed at any time.
7. Provide all concrete slab on grade demolition inside of building, as indicated in the construction documents, **specifically as shown on Architectural and MEP demolition drawings**. Concrete slabs that are to be removed for removal/installation of new building systems shall be coordinated with the Mechanical & Plumbing Contractor and Electrical Contractor as required. Layout of slab demolition related to building systems shall be provided by the Mechanical & Plumbing Contractor and Electrical Contractor. Maintain all utilities that will remain. **(BPA ADDENDUM NO. 2)**
8. All foundation walls, areaway walls shall be demolished completely. The area will be backfilled, **by this contractor**, with suitable materials to match existing grade. **(BPA ADDENDUM NO. 2)**
9. Items of demolition shall include, but not necessarily be limited to, complete or partial structures, wall framing, masonry walls, structural steel, interior partitions, roofing, **flooring and mastic**, mechanical and electrical equipment and fixtures, fire protection systems and related equipment. **(BPA ADDENDUM NO. 2)**
10. Remove all oil and fuel storage tanks that are located within the structure in accordance with all City, State and Federal regulations. This work will be performed by a contractor licensed to perform this work. The existing 1,500 gallon above ground oil tank referenced on Drawing C2 has been removed by owner and will not be the responsibility of this Contractor.
11. This Contractor shall notify the Construction Manager immediately if hazardous materials (i.e. asbestos, lead, PCB's, etc.) are uncovered. At that time, all work in the affected area will be stopped until proper removal can be completed by others (i.e. hazardous material abatement contractor).
12. Temporary maintenance standby labor such as for temporary water, temporary power, temporary light and the like where required due to this Contractor's work is to be included within the Contract Price.
13. If this Project is to be constructed adjacent to existing buildings or portions thereof to remain, this Contractor shall exercise all due precautions to minimize noise, air pollution

and any other construction hazards which in any way would cause discomfort or danger to the occupants of the existing buildings in the area.

14. This Contractor shall clean public streets and sidewalks daily of debris resulting from its operations. This Contractor shall collect and remove from the site daily all rubbish, scrap and other debris resulting from its operations.
15. This Contractor shall include in the Contract Price and unit prices, the cost of all police traffic details required for the execution of the Work.
16. This Contractor shall comply with all Federal, State and local laws requiring noise control and hours which work is to be conducted. Mufflers, "whisperized" compressors, etc., shall be used as required for compliance with laws and ordinances throughout the course of the Work.
17. It is understood that all Work under this Contract shall be in strict accordance with the Building Code with the City, State and any other agency having jurisdiction. In the event of any conflict in any provisions of any regulatory agency and Contract Documents, the more stringent requirements shall apply.
18. This Contractor is aware of the structural capacities of various portions of the structure. Cranes, materials, deliveries and material storage, shall not exceed rated capacities without this Contractor taking appropriate steps to compensate for the imposition of loads which may exceed the design criteria and which are imposed solely by this Contractor's operations.
19. This Contractor shall provide any and all "fire watch" personnel required due to this Contractor's cutting, burning, welding or other open flame activity.
20. This Contractor shall submit proposed methods and operations of building demolition to the Owner, his representative or agents for review at least (15) business days prior to the start of work, including a schedule of coordinating the shut off, capping and/or continuation of utility services as required.
21. This Contractor shall visit the site of the proposed work, fully acquaint and familiarize himself with the conditions as they exist and the character of the operations to be carried out under the proposed Contract, and make such investigation as he may see fit so that he shall fully understand the facilities, physical conditions and restrictions affecting the work under the Contract. Claims for additional compensation and/or extensions of time because of Contractor's failure to familiarize himself with all conditions which might affect the work shall not be allowed.
22. Before proceeding with the demolition work, this Contractor shall protect all public sidewalks, streets or thoroughfares and all property adjacent to the site as required by such codes, ordinances, rules and regulations, including, but not limited to, scaffolding, sidewalk bridges, fences, barricades, aprons, warning signs and lights. This Contractor

- shall coordinate with the Owner to provide proper demolition notice to the DNREC Division of Air Quality, prior to proceeding with demolition activities.
23. This Contractor, before commencement of any part of the Work, shall give any notices, required to be given to an adjoining landowner and other parties.
  24. This Contractor shall maintain all required means of egress from the existing buildings and alter such stairs, platforms and fire escapes as required to satisfy all agencies having jurisdiction.
  - ~~25. Before demolition work is started, existing sewer, water, gas and other service lines to the existing buildings shall be shut off, disconnected and capped or plugged in accordance with the requirements of the utility companies or other authorities having jurisdiction. This Contractor shall notify all such authorities in advance and obtain their approval and cooperation in shutting off utilities. All costs associated with disconnecting utilities shall be borne by this Contractor. (BP1 ADDENDUM NO. 2)~~
  26. This Contractor shall take special precautions to shore, brace, support or relocate any utility lines as may be required to satisfy all agencies having jurisdiction.
  27. Any existing piping, subsoil drainage systems, conduit, manholes, tanks, catch basins, etc., which are abandoned shall be plugged with concrete and to the extent within or beneath the limits of excavation, removed. All others are to be maintained and repaired or otherwise restored to proper operating condition.
  - ~~28. This Contractor shall, in cooperation with utility companies, remove or cause to be removed all light and power poles if required to be removed, at such time as the services utilizing said poles are no longer required. (BP1 ADDENDUM NO. 2)~~
  - ~~29. If required, this Contractor shall relocate power or light poles, fire hydrants, traffic signs or signals and similar utility and public service items in use and shall cooperate with all governmental agencies having jurisdiction over such items so as not to interfere with the services of such governmental agencies. (BP1 ADDENDUM NO. 2)~~
  30. Street openings made for the shutting off or tapping of utility lines or for any other purpose shall be backfilled, tamped and the surfaces restored in accordance with the requirement of applicable local codes or to match existing; whichever is greater.
  31. Existing services to remain will be defined by the Owner prior to or immediately after the start of demolition work.
  32. Utility equipment belonging to the utility companies, if to be retained by these companies, will be removed from the site by the company owning the equipment upon timely notification by this Contractor.
  33. This Contractor shall make a careful examination of the structures to be demolished and

- the adjoining property and utilities which are to remain; take whatever precautions are necessary and carry on operations so as to prevent personal injury and any settlement, collapse, damage from falling debris or other causes to adjacent building.
34. Any damage to public property, private property, or to utilities due to demolition operations, or the Contractor's neglect, shall be corrected by this Contractor, in a manner approved by the Owner and the parties whose property has been damaged, all at no additional cost to the Owner.
  35. Miscellaneous equipment and furnishings belonging to the Owner, if to be retained by the Owner, will be removed before the commencement of the demolition work. All other equipment or furnishings attached, remaining, in the building at the start of the demolition work shall become the property of this Contractor and shall be removed and disposed of by this Contractor.
  36. All equipment, materials and debris shall be regularly removed by this Contractor from the Site as work progresses in such manner as not to create a nuisance, and shall be disposed of by this Contractor at his own expense, at locations to be determined by this Contractor. Permits required in connection with the disposal of the materials shall be obtained by this Contractor. Disposal shall be in accordance with all Federal, State and local laws, rules, codes, orders and regulations.
  37. Materials and equipment to be salvaged or which have been sold to others by this Contractor must be promptly removed by this Contractor, and shall not be stored at the site. The offering, advertising, display or sale of materials and equipment will not be permitted.
  38. Contractor shall remove debris promptly and will not burn anything on the site. Contractor shall keep required fire extinguishing equipment in serviceable condition, properly distributed so that it will be available for immediate use, particularly during any acetylene cutting operations. This Contractor shall afford adequate facilities for inspection by, and carry out the recommendations of, the local Fire Department. This Contractor shall maintain one fire riser during demolition.
  39. This Contractor shall, prior to the start of Work, provide the name and location of proposed dump site to receive the demolition debris. Dump site must be licensed and acceptable to all local government agencies having jurisdiction.
  40. This Contractor shall provide signed and stamped dump site debris tickets identifying the location, date, time and quantity of debris deposited at the dump site.
  41. This Contractor shall remove existing playground equipment, bollards, fencing, benches, bike racks, flag poles, and basketball goals including foundations, pads, structures, and supports.
  42. This Contractor shall remove existing trash compactor and controls. Contractor shall

- coordinate with ASD for timely removal of trash compactor receiver box.
43. This Contractor shall sawcut and remove existing portions of building slab as indicated in the construction documents.
  44. This Contractor shall provide all shoring and supports needed to properly secure existing structure that will remain after the execution of the scope of this Contractor's Contract.
  45. All costs for barricades, arrows, pedestrian protections, flag men, etc. will be part of this Contract. It shall be assumed there is at least 1 marked flagger to escort trucks through the project site.
  46. Provide daily fine cleanup of the work is the responsibility of each individual Contractor which includes broom cleaning of their debris as required. Daily Fine clean up, on a daily basis, shall be defined as those means/methods utilized to perform the daily cleaning tasks without producing dust, noise and stacking of stored materials. Furnish fine clean up on a daily basis. All debris must be removed from the work area at the end of each work day to the appropriate dumpster.
  47. Provide at least a 48 hour notice prior to any delivery. All deliveries are to be between 7:00 AM and 3:30 PM.
  48. This is not a secure site. All contractors are responsible for concealing, locking and/or removing any materials on a daily basis. ASD and EDiS will not be responsible for any lost tools, materials or equipment.
  49. Provide a \$50,000 allowance, included in base bid, to be used at the discretion of the Construction Manager.
  50. **The Demolition Contractor will be responsible for complete demolition of the roofing systems in all locations where existing roof deck is removed. The Demolition Contractor shall coordinate layout and extent of demolition at the roof assembly type RA-09 with Carpentry and General Works Contractor and Structural Steel Contractor – Demolition layout in these locations will be provided by the Carpentry and General Works Contractor. The Roofing Contractor will be responsible for complete demolition of roofing systems in all locations where existing roof deck will remain. (BP1 ADDENDUM NO. 2)**

CONTRACT NO. A-02 - SITEWORK

A. Work included in this contract consists of, but is not necessarily limited to, all labor, materials and equipment for:

- Technical Specification Sections:

Division 0	Bidding and Contract Requirements
Division 1	General Requirements
Section 033000	Cast-in-Place Concrete
<del>Section 079100</del>	<del>Preformed Joint Seals (BP1 ADDENDUM NO. 2)</del>
Section 079200	Joint Sealants
Section 107516	Ground-Set Flag Poles
Section 116800	Play Field Equipment and Structures
<del>Section 260130</del>	<del>Manholes (BP1 ADDENDUM NO. 2)</del>
Division 22	Plumbing
Division 26	Electrical

This contract also includes, but is not necessarily limited to, all labor, materials and equipment for the following:

1. Provide sitework, site clearing, landscaping, fiber lines, storm, sanitary and water utilities, concrete & asphalt paving, all exterior concrete, tree grates, signage & striping, curbs, walks and topsoil/seeding.
2. Provide layout of this contract work from a licensed surveyor.
3. Before ANY excavation work is to commence, the Contractor/Excavator shall contact the utility companies or utility owners and advise them of the proposed work and ask them to mark the location of the underground utility installations. This notification shall be done within established or customary local response times. If the work is on private property and the utility company will not mark out the utilities, the Contractor/Excavator will hire a private locating service to mark the utilities. Once the utilities are located and marked, the Contractor/Excavator will excavate by hand or use a vacuum truck to expose the utilities and record the exact location and elevation of the utilities. The Contractor/Excavator must submit the Excavation Permit to EDiS Company verifying their assurance of communication with the utility companies or utility owners. The Contractor/Excavator must follow State, Local, and Federal Guidelines prior to proceeding with excavations. The Contractor/Excavator will have these marks restored as long as there is work to perform. Once the Contractor has installed new utilities, they will provide to EDiS Company an as-built drawing, within 7 days, showing the exact location and elevation of the utilities. The installing Contractor will be responsible for locating and marking these utilities for other contractors that may have work in the same area.
4. Furnish, install, maintain and remove sediment control system including sediment control plan. Maintain sediment control until substantial completion has been established by



- DNREC.
5. Coordination and cooperation with a certified construction reviewer (CCR), contracted by the Appoquinimink School District.
  6. Provide, maintain, and remove at the end of the project the stabilized site entrances as required by DNREC.
  7. Provide, maintain, and remove at the end of the project the concrete washout station(s) as required by DNREC. The washout station(s) will be used by all contractors on the project.
  8. Protect all existing trees to remain within the limits of construction.
  9. Clearing, grubbing and removal of trees, roots and stumps.
  10. Saw cutting and removal of sidewalks, curbs, etc. in the performance of work is this Contractor's responsibility.
  11. Remove/relocate utilities including, but not limited to the removal of light standards.
  12. Topsoil stripping and stockpiling on site, and subsequent maintenance. Topsoil will be spread after the sidewalks and roadways are complete. This contractor will furnish and install any additional topsoil required to meet final grades.
  13. Rough grading for area defined on site drawings for building, lawn areas, bituminous roads, parking and walkways. Preparation of subgrade for building slabs, walks and pavements.
  14. ~~The Sitework Contractor will be performing the foundation excavation for the Concrete Contractor. The Concrete Contractor will be responsible for laying out all concrete work as shown on the structural and architectural drawings. This work is to be closely coordinated between the Sitework Contractor and the Concrete Contractor. It will be the responsibility of the Sitework Contractor to maintain all open excavations and dewater as specified until the excavation work is turned over to the Concrete Contractor. Once the Concrete Contractor has accepted this work it will be the responsibility of the Concrete Contractor to maintain and dewater all excavations until the concrete work is complete at which time dewatering will be the responsibility of the Sitework Contractor until final acceptance. The Concrete Contractor and the Sitework Contractor are to coordinate this procedure so that there are no additional costs to the Owner for additional excavation or concrete. (BP1 ADDENDUM NO. 2)~~
  15. Furnish, install and maintain select fill under slab. The Sitework Contractor will bring the area beneath the building to an elevation that is 8-inches below finished concrete elevation. The area will then be turned over to the Concrete Contractor who will be excavating and installing the foundations. It will be the responsibility of the Sitework Contractor to maintain all open excavations and dewater as specified until the excavation work is turned

over to the Concrete Contractor. Once the Concrete Contractor has accepted this work it will be the responsibility of the Concrete Contractor to maintain and dewater all excavations until the concrete work is complete. The Concrete Contractor and the Sitework Contractor are to coordinate this procedure so that there are no additional costs to the Owner for additional excavation or concrete. Backfilling around the foundation walls, inside and outside, will be the responsibility of the Concrete Contractor.

16. Filling and backfilling as detailed below is the responsibility of this Contractor. Soil types shall be in accordance with project documents. It is the intent to use imported fill within the foot print of the building, plus a 10 foot zone around the entire perimeter of the building. It is the intent to use on site material and not imported fill as much as practicable. The use of this onsite material shall conform with the compaction requirements as specified on the drawings and in the specifications. There is not enough fill material on the site. Therefore, importing of material is required, and shall be included in the cost of the work. If it is determined by the testing agency that the onsite material is unsatisfactory material, then the material shall be removed and replaced at a unit price for select fill.
17. Provide temporary excavation shoring to support and maintain adjacencies.
18. Proof rolling of limit of excavation prior to the start of fill operations.
19. Provide water meter pit (vault), **which this Contractor shall purchase from the Town of Middletown. This Contractor shall be responsible for coordination with Town of Middletown, Department of Public Works. (BP1 ADDENDUM NO. 2)**
20. Furnish, install, maintain and remove temporary site fencing at the completion of the project. Temporary fencing shall consist of 2000' of 6'-0" chain link fencing sections. There will also be (2) 24-foot construction gates that will need to be mounted at each end of the entrances in to the new school. These gates will need to be lockable.
21. All new utilities shall be brought to within +/- 5 feet of the building line by this Contractor. The connection and all utilities from +/- 5 feet and into the building shall be by others.
22. Third party testing for on-site quality control (soil compaction, concrete, asphalt, etc.) will be provided by the Owner.
23. This Contractor will provide all temporary and permanent pavements markings, painted curbs at fire lanes, fire lane signs, and traffic signs.
24. Provide pre-cast concrete parking bumpers.
25. Provide caulk and joint sealants for work under this contract.
26. This Contractor shall include in the base bid the cost of remobilization, cleaning and tack coating the asphalt base course in order to install the asphalt top coat.

27. Include all costs for traffic maintenance, temporary signage, temporary barricades, arrows, pedestrian protection, flagmen, etc. required to complete the work. It shall be assumed there is at least 1 marked flagger to escort trucks through the project site.
28. Provide perimeter protection of all excavated areas until suitably backfilled.
29. Provide street cleaning of mud, etc. on a daily basis for ALL Contractors throughout the entire construction period.
30. Provide all playground equipment and playground exposed and subsurface material installations including grading, preparation of subbase, foundations, protective playground surfacing, equipment erection, fencing, and all playground accessories. This shall also include all excavations, foundations, backfilling of equipment bases.
31. Provide potable temporary water services via frost-free yard hydrant from existing water service outside of building for sitework and dust control. Include all costs associated with metering from local utilities as well as valves and hoses for contractors to utilize. The Construction Manager will not provide this service.
32. Provide all plant material and all associated work including, but not limited to, staking, watering, weeding, **mowing**, etc. **Provide topsoil testing and necessary soil amendments, as required. (BP1 ADDENDUM NO. 2)**
33. Planting soil mix in beds and topsoil to be provided by this Contractor. Provide all additional soil mix required to set plant materials and final grading.
34. Provide filter fabric, weed, check and mulch.
35. Provide all temporary and permanent soil stabilization, including sod and seed turf, as indicated in the construction documents and as required by the delegated agency.
36. Provide specified warranties. All landscape plant material to be guaranteed for a period of two years from the date of owner acceptance. If Sitework contractor is not responsible for maintaining the property during the guarantee period, they shall be responsible for making monthly inspections and issuing written reports as indicated in the Documents.
37. A complete copy of the project soils report is available for inspection in the Project Manual. Contractors should carefully review the soil borings as they relate to the extent of rubble to be removed and other man made obstructions.
38. This Contractor shall provide all asphalt concrete paving and portland cement concrete paving, sidewalks and curbs, excluding concrete for duct banks, light standards and any other concrete work specifically related to the electrical work. Asphalt paving scope shall include all milling, overlay, and full depth paving restoration.
39. ASPHALT CEMENT COST ADJUSTMENT

- a. Payments to the Contractor shall be adjusted to reflect increase or decreases in the Delaware Posted Asphalt Cement Price when compared to the Project Asphalt Cement Base Price, as defined in these Special Provisions.
  - b. The Delaware Posted Asphalt Cement Price will be issued monthly by the Department and will be the industry price for Asphalt Cement, F.O.B. Philadelphia, Pennsylvania.
  - c. All deviations of the Delaware Posted Asphalt Cement Price from the Project Asphalt Cement Base Price are eligible for cost adjustment. No minimum increases or decreases or corresponding percentages are required to qualify for cost adjustment.
  - d. Actual quantity of asphalt cement qualifying for any Asphalt Cement Cost Adjustment will be computed based on weight tickets and asphalt percentage from the approved job mix formula.
  - e. For Recycled Hot-Mix the asphalt percentage eligible for cost adjustment shall be only the new asphalt cement added to the mix.
  - f. The Asphalt cement cost adjustment will be calculated on grade PG 64-22 asphalt regardless of the actual grade of asphalt used. The Project Asphalt Cement Base Price for the project will be based on the September 2015 price posted on DelDOT's website.
  - g. If the Contractor exceeds the authorized allotted completion time, the price of asphalt cement on the last authorized allotted work day, shall be the prices used for cost adjustment. However, if the industry posted price for asphalt cement goes down, the asphalt cement cost shall be adjusted downward accordingly.
40. Provide off-site disposal of all unsuitable excavated materials.
  41. Provide the ornamental site fence and permanent exterior gates, including all hardware. The excavation, installation of foundations and backfilling for fence piers will be completed by the Sitework Contractor. The masonry will be provided by Masonry contractor. Hardware for permanent exterior gates will be provided by the Sitework Contractor and installed by Carpentry & General Works Contractor. Access control hardware/software and fire alarm integrations of gate hardware, including terminations, cabling, etc. will be provided by the Special Systems Contractor. The Electrical Contractors shall provide all pathways & electrical requirements to support installation.
  42. Provide all site amenities including but not limited to flag poles, ~~trash compactor (and controls)~~, bike racks, benches, trash cans, basketball goals, etc. **(BP1 ADDENDUM NO. 2)**
  43. Provide all labor, material, trucking, equipment, disposal, hoisting, scaffolding, power, temporary facilities, supervision, layout, clean up, etc. for the complete performance of all demolition work outside of the existing building including site concrete, hot mix paving, retaining walls (concrete and masonry) in a legal manner. Remove all concrete (including hot mix, brick and stone) curbs and sidewalks on as shown. Maintain all utilities. This contractor is responsible for all the demolition notes detailed on drawings C2. The utility relocations as detailed on C4 will be performed by the Sitework Contractor. The Sitework Contractor will coordinate and cooperate with the utility companies while the work is being performed. **This Contractor shall provide restoration of all site features as necessary due to the installation the site lighting system installation as shown on Drawing E50.1, including coordination with Electrical Contractor. (BP1 ADDENDUM**

**NO. 2)**

44. Any existing piping, subsoil drainage systems, conduit, manholes, tanks, catch basins, etc. which are abandoned shall be plugged with concrete and, to the extent within or beneath the limits of excavation, removed. All others are to be maintained and repaired or otherwise restored to proper operating condition.
45. Remove from site all combustible material including, but not limited to wood, steel, iron, structural steel, and dispose of in a legal manner. No on site burning of material will be allowed at any time.
46. Remove from site concrete slabs on grade, hot mix paving, retaining walls (concrete and masonry) in a legal manner.
47. This Contractor shall notify the Construction Manager immediately if hazardous materials (i.e. asbestos, lead, PCB's, etc.) are uncovered. At that time, all work in the affected area will be stopped until proper removal can be completed by others (i.e. hazardous material abatement contractor).
48. Temporary maintenance standby labor such as for temporary water, temporary power, temporary light and the like where required due to this Contractor's work is to be included within the Contract Price.
49. This Project is to be constructed adjacent to existing buildings, this Contractor shall exercise all due precautions to minimize noise, air pollution and any other construction hazards which in any way would cause discomfort or danger to the occupants of the existing buildings in the area.
50. This Contractor shall comply with all Federal, State and local laws requiring noise control and hours which work is to be conducted. Mufflers, "whisperized" compressors, etc., shall be used as required for compliance with laws and ordinances throughout the course of the Work.
51. It is understood that all Work under this Contract shall be in strict accordance with the Building Code with the County, State and any other agency having jurisdiction. In the event of any conflict in any provisions of any regulatory agency and Contract Documents, the more stringent requirements shall apply.
52. This Contractor is aware of the structural capacities of various portions of the structure. Cranes, materials, deliveries and material storage, shall not exceed rated capacities without this Contractor taking appropriate steps to compensate for the imposition of loads which may exceed the design criteria, and which are imposed solely by this Contractor's operations.
53. This Contractor shall provide any and all "fire watch" personnel required due to the Contractor's cutting, burning, welding or other open flame activity.

54. This Contractor shall submit proposed methods and operations of building demolition to the Owner, his representative or agents for review prior to the start of work, including a schedule of coordinating the shut off, capping and/or continuation of utility services as required.
55. This Contractor, in the performance of the Work under his subcontractor, shall maintain all required means of egress from the existing buildings as required to satisfy all agencies having jurisdiction.
56. ~~Before demolition work is started, existing sewer, water, gas and other service lines to the existing buildings shall be shut off, disconnected and capped or plugged in accordance with the requirements of the utility companies or other authorities having jurisdiction. This Contractor shall notify all such authorities in advance and obtain their approval and cooperation in shutting off utilities. All costs in connection with disconnecting utilities shall be borne by this Contractor. (BP1 ADDENDUM NO. 2)~~
57. This Contractor shall take special precautions to shore, brace, and support or relocate any utility lines as may be required to satisfy all agencies having jurisdiction.
58. This Contractor shall, in cooperation with utility companies, remove or cause to be removed all light and power poles if required to be removed, at such time as the services utilizing said poles are no longer required.
59. If required, this Contractor shall relocate power or light poles, fire hydrants, traffic signs or signals and similar utility and public service items in use and shall cooperate with all governmental agencies having jurisdiction over such items so as not to interfere with the services of such governmental agencies.
60. Street openings made for the shutting off or tapping of utility lines or for any other purpose shall be backfilled, tamped and the surfaces restored in accordance with the requirement of applicable local codes or to match existing; whichever is greater.
61. Existing services to remain will be defined by the Owner prior to or immediately after the start of demolition work.
62. Utility equipment belonging to the utility companies, if to be retained by these companies, will be removed from the site by the company owning the equipment upon notification by this Contractor.
63. This Contractor shall make a careful examination of the structures to be demolished and the adjoining property and utilities which are to remain; take whatever precautions are necessary and carry on operations to prevent personal injury and any settlement, collapse, damage from falling debris or other causes to adjacent building.
64. Any damage to public property, private property, or to utilities due to demolition

operations, or the Contractor's neglect, shall be corrected by this Contractor, in a manner approved by the Owner and the parties whose property has been damaged, all at no additional cost to the Owner.

65. Miscellaneous equipment and furnishings belonging to the Owner, if to be retained by the Owner, will be removed before the commencement of the demolition work. All other equipment or furnishings attached, remaining, in the building at the start of the demolition work shall become the property of this Contractor and shall be removed and disposed of by this Contractor.
66. All equipment, materials and debris shall be regularly removed by this Contractor from the Site as work progresses in such manner as not to create a nuisance and shall be disposed of by this Contractor at his own expense, at locations to be determined by this Contractor. Permits required in connection with the disposal of the materials shall be obtained by this Contractor. Disposal shall be in accordance with all Federal, State and local laws, rules, codes, orders and regulations.
67. The offering, advertising, display or sale of salvaged materials and equipment will not be permitted.
68. Contractor shall remove debris promptly and will not burn anything on the site. Contractor shall keep required fire extinguishing equipment in serviceable condition, properly distributed so that it will be available for immediate use, particularly during any acetylene cutting operations. This Contractor shall afford adequate facilities for inspection by, and carry out the recommendations of, the local Fire Department. This Contractor shall maintain one fire riser during demolition.
69. This Contractor shall, prior to the start of Work, provide the name and location of proposed dump site to receive the demolition debris. Dump site must be licensed and acceptable to all local government agencies having jurisdiction.
70. This Contractor shall provide signed and stamped dump site debris tickets identifying the location, date, time and quantity of debris deposited at the dump site.
71. Provide daily fine cleanup of the work is the responsibility of each individual Contractor which includes broom cleaning of their debris as required. Daily Fine clean up, on a daily basis, shall be defined as those means/methods utilized to perform the daily cleaning tasks without producing dust, noise and stacking of stored materials. Furnish fine clean up on a daily basis. All debris must be removed from the work area at the end of each work day to the appropriate dumpster.
72. Provide at least a 48-hour notice prior to any delivery. All deliveries are to be between 7:00 AM and 3:30 PM.
73. This is not a secure site. All contractors are responsible for concealing, locking and/or removing any materials on a daily basis. ASD and EDiS will not be responsible for any lost

tools, materials or equipment.

74. Provide a \$50,000 allowance, included in base bid, to be used at the discretion of the Construction Manager.
75. **Provide an allowance, included in base bid to furnish, install, and maintain 22,000 square feet of 8-inch-thick stone base and geotextile fabric for access around the construction site, to be used at the discretion of the Construction Manager. This allowance will include removal and disposal of this material prior to final grading and spreading of topsoil. (BP1 ADDENDUM NO. 2)**
76. **Provide an allowance, included in base bid to furnish, install, and maintain (4) crane pads (40' x 25') with 8-inch-thick stone base to be used at the discretion of the Construction Manager. This allowance will include removal and disposal of this material prior to final grading and spreading of topsoil. (BP1 ADDENDUM NO. 2)**



CONTRACT NO. A-03 - CONCRETE

A. Work included in this contract consists of, but is not necessarily limited to, all labor, materials and equipment for:

- Technical Specification Sections:

Division 0	Bidding and Contract Requirements
Division 1	General Requirements
Section 033000	Cast-In-Place Concrete
Section 033600	Concrete Floor Sealer
<del>Section 071900</del>	<del>Water Repellants</del> (BP1 ADDENDUM NO. 2)
Section 072100	Thermal Insulation
Section 079100	Preformed Joint Seals
Section 079200	Joint Sealants

This contract also includes, but is not necessarily limited to, all labor, materials and equipment for the following:

1. Provide concrete foundations, all slabs on grade/deck and all reinforcing steel. **This shall include all slab replacement at interior trenches created during the installation of plumbing, mechanical, and electrical systems. This Contractor shall coordinate locations and layout of replacement slabs with the Demolition, Mechanical & Plumbing, and Electrical Contractors. (BP1 ADDENDUM NO. 2)**
  
2. This Contractor will be responsible for laying out all concrete work as shown on the structural and architectural drawings. ~~Concrete work is to be coordinated with the Sitework Contractor who will be performing the excavation for this Contractor. It will be the responsibility of the Sitework Contractor to maintain all open excavations and dewater as specified until the excavation work is turned over to this Contractor. Once this Contractor has accepted this work it will be the responsibility of this Contractor to maintain and dewater all excavations until the concrete work is complete at which time dewatering will be the responsibility of the Sitework Contractor until final acceptance. This Contractor and the Sitework Contractor are to coordinate this procedure so that there are no additional costs to the Owner for additional excavation or concrete. The Sitework Contractor will furnish, install and maintain select fill under slab. The Sitework Contractor will bring the area beneath the building to an elevation that is 8-inches below finished concrete elevation. The area will then be turned over to the Concrete Contractor who will be excavating and installing the foundations. It will be the responsibility of the Sitework Contractor to maintain all open excavations and dewater as specified until the excavation work is turned over to the Concrete Contractor. Once the Concrete Contractor has accepted this work it will be the responsibility of the Concrete Contractor to maintain and dewater all excavations until the concrete work is complete. The Concrete Contractor and the Sitework Contractor are to coordinate this procedure so that there are no additional costs to the Owner for additional excavation~~

or concrete. Backfilling around the foundation walls/footers, inside and outside, will be the responsibility of the Concrete Contractor. The Concrete Contractor will also be responsible for additional excavation and backfilling within the building as may be required to accommodate the raised floors, utility trenches, varying slab thicknesses, depressed slabs and grade changes. Close coordination with the Sitework, Masonry, Mechanical and Electrical Contractors is required. (BP1 ADDENDUM NO. 2)

3. This Contractor to furnish and install reinforcing steel, admixtures, curing compound, sealers as required in the Contract Documents for all work associated with this contract.
4. Perimeter insulation at foundation walls.
5. Underslab vapor barrier, insulation, reglets, waterstops, control and construction joints (including required caulking at control and construction joints).
6. Placement of related items furnished under other Specification Sections.
7. Provide certified anchor bolt verification drawings to the Construction Manager for review prior to steel erection. Anchor bolts and leveling plates to be installed by this Contractor and furnished by the Structural Steel contractor. Installation within required tolerances. Anchor bolt assemblies to be placed with templates only. This Contractor shall supply as-built drawings to steel erector for coordination prior to steel placement.
8. All blockouts and embedments required by plans and specifications.
9. This Contractor to install all sleeves for incoming utilities at the perimeter walls and/or foundations. Sleeves will be provided by respective contractor(s).
10. This Contractor is responsible for grouting all structural steel base or leveling plates.
11. Include all weather, frost protection, and water pumping as required. This Contractor is also responsible for the premiums required for hot water, heated aggregate and admixtures for hot or cold weather concrete.
12. Coordinate the "Notch" in the concrete slabs to allow for a future Contractor to easily install expansion joint details.
13. Provide and maintain perimeter fall protection at all excavated areas per OSHA standards.
14. Equipment bases and foundations shall be the responsibility of the Contractor providing the equipment.
15. Asphalt concrete paving and portland cement concrete paving, sidewalks and curbs shall be provided by others.
16. All concrete testing will be completed by the Construction Manager, however, it will be

the responsibility of this Contractor to furnish all samples. CM Note: Construction Manager to ensure that FF/FL compliance is verified by an independent testing agency within 48 hours of completion of pour, per ACI (Section 8.15.4). Also, a report must be provided to the concrete contractor within 72 hours of pour per ACI.

17. Provide specified sloping for floor drains/trenches in kitchen, showers, as detailed in the Construction Documents (Drains to be furnished and installed by Mechanical/Plumbing Contractor.) The Mechanical/Plumbing Contractor and this Contractor are to coordinate drain rim elevation to achieve positive drainage and ensure that there are no additional costs to the Owner for field adjustments.
18. Provide depressed slab in kitchen area for walk-in cooler and freezer units. Provide grout bed **and reinforcement in under** cooler, and freezer, ~~and dry storage~~. Coordinate with Kitchen Equipment Contractor **for proper sequencing. (BP1 ADDENDUM NO. 2)**
19. This Contractor shall include the finishing of concrete slabs **at** all floor penetrations. These penetrations will consist of electrical boxes, stubbed conduits, mechanical piping and electrical and technology conduit stubs, etc. **(BP1 ADDENDUM NO. 2)**
20. This Contractor shall provide written documentation that all concrete slabs are within the tolerance required by the contract documents. Testing and analysis to be paid for by this Contractor.
21. This Contractor shall include a minimum of two additional out of sequence remobilizations for concrete slab installation.
22. All costs for barricades, arrows, pedestrian protections, flag men, etc. will be part of this Contract. It shall be assumed there is at least 1 marked flagger to escort trucks through the project site.
23. Provide daily fine cleanup of the work is the responsibility of each individual Contractor which includes broom cleaning of their debris as required. Daily Fine clean up, on a daily basis, shall be defined as those means/methods utilized to perform the daily cleaning tasks without producing dust, noise and stacking of stored materials. Furnish fine clean up on a daily basis. All debris must be removed from the work area at the end of each work day to the appropriate dumpster.
24. Provide at least a 48 hour notice prior to any delivery. All deliveries are to be between 7:00 AM and 3:30 PM.
25. This is not a secure site. All contractors are responsible for concealing, locking and/or removing any materials on a daily basis. ASD and EDiS will not be responsible for any lost tools, materials or equipment.
26. Provide a \$10,000 allowance, included in base bid, to be used at the discretion of the Construction Manager.

CONTRACT NO. A-04 - MASONRY

A. Work included in this contract consists of, but is not necessarily limited to, all labor, materials and equipment for:

- Technical Specification Sections:

Division 0	Bidding and Contract Requirements
Division 1	General Requirements
Section 042000	Unit Masonry
Section 047200	Cast Stone Masonry
Section 071900	Water Repellants
Section 072100	Insulation
Section 072119	Foamed-in-Place Insulation
<b>Section 076200</b>	<b>Sheet Metal Flashing and Trim (BP1 ADDENDUM NO. 2)</b>
Section 079100	Preformed Joint Seals
Section 079200	Joint Sealants

This contract also includes, but is not necessarily limited to, all labor, materials and equipment for the following:

1. Provide masonry units, reinforcing, accessories and related work.
2. Provide caulking of masonry to masonry and to dissimilar materials.
3. Provide integral masonry flashings, expansion joints, insulation, spray foam insulation, and other related items as required. **This Contractor shall cut masonry reglets and install masonry flashings at interface between new and existing construction, as required. (BP1 ADDENDUM NO. 2)**
4. Provide mock up as required.
5. Provide grouting of door frames at masonry openings.
6. Provide weather protection and temporary heat as required to perform the work and maintain the project schedule.
7. Provide scaffolding as required to complete the work.
8. Provide dewatering of work areas.
9. Provide layout of the work including responsibility for all elevations and dimensions as they affect other Contractor's work. This Contractor shall coordinate layout with Construction Manager and other subcontractors.

10. ~~Provide and install pre-cast concrete lintels as indicated in the Construction Documents.~~ Provide masonry lintels and/or install loose lintels furnished by others. This shall include attaching the loose lintels to the structure with bolts, fasteners, welding, etc. This Contractor will review the mechanical, plumbing and electrical drawings to determine the quantity and location of lintels that will be required where these utilities pass through masonry walls. This Contractor will coordinate with the Mechanical & Plumbing, Structural Steel & Misc. Metals, and Electrical Contractors to establish the layout and elevations before installing lintels. (BP1 ADDENDUM NO. 2)
11. ~~Coordinate and installation of loose lintels furnished by Structural Steel & Miscellaneous Metals Contractor.~~
12. Provide bond beams including reinforcing and fill.
13. Provide fill at hollow concrete masonry units.
14. Provide coordination and setting of reinforcing steel in block walls.
15. Provide cementitious parging.
16. **Provide all Cast stone/Limestone work. (BP1 ADDENDUM NO. 2)**
17. Temporary protection for final wash down/cleaning of masonry.
18. Flashing Summary:
  - a. Thru wall and cavity flashing below the **relative** roof line shall be provided by the Masonry Contractor. (BP1 ADDENDUM NO. 2)
  - b. Thru wall and cavity flashing above the **relative** roof line shall be provided by the Roofing Contractor. (BP1 ADDENDUM NO. 2)
19. Provide cutting, fitting and building into masonry work, embedments **of elements not provided by this contract shall be** provided by others. (BP1 ADDENDUM NO. 2)
20. Provide all firesafing and fire caulking as required for all work related to masonry work. **This includes fire resistant and compressible filler at the top of all masonry walls, as required. (BP1 ADDENDUM NO. 2)**
21. Provide all masonry **and masonry** veneer anchors where required. **This Contractor shall cut pockets in existing exterior masonry, grout solid as required, and restore masonry veneer. (BP1 ADDENDUM NO. 2)**
22. Provide the masonry in the fence piers. The excavation, installation of foundations and backfilling for masonry piers will be completed by the Sitework Contractor. The fence will be provided by Structural Steel & Miscellaneous Metals contractor.
23. This contractor shall be responsible for removal of all masonry debris and trash associated

- with new construction.
24. Include filling of all interior hollow metal door frames in drywall where required.
  25. All costs for barricades, arrows, pedestrian protections, flag men, etc. will be part of this Contract. It shall be assumed there is at least 1 marked flagger to escort trucks through the project site.
  26. Provide daily fine cleanup of the work is the responsibility of each individual Contractor which includes broom cleaning of their debris as required. Daily Fine clean up, on a daily basis, shall be defined as those means/methods utilized to perform the daily cleaning tasks without producing dust, noise and stacking of stored materials. Furnish fine clean up on a daily basis. All debris must be removed from the work area at the end of each work day to the appropriate dumpster.
  27. Provide at least a 48 hour notice prior to any delivery. All deliveries are to be between 7:00 AM and 3:30 PM.
  28. This is not a secure site. All contractors are responsible for concealing, locking and/or removing any materials on a daily basis. ASD and EDiS will not be responsible for any lost tools, materials or equipment.
  29. Provide a \$20,000 allowance, included in base bid, to be used at the discretion of the Construction Manager.
  30. **Provide water repellants. (BP1 ADDENDUM NO. 2)**
  31. **Provide all spray foam (foamed-in-place) insulation including but not limited to interior cavity walls (regardless of substrate or veneer), new spray foam insulation/vapor barrier beneath roof assemblies, as shown on Drawing A20.1. (BP1 ADDENDUM NO. 2)**

CONTRACT NO. A-05 - STRUCTURAL STEEL & MISCELLANEOUS METALS

A. Work included in this contract consists of, but is not necessarily limited to, all labor, materials and equipment for:

- Technical Specification Sections:

Division 0	Bidding and Contract Requirements
Division 1	General Requirements
Section 051200	Structural Steel Framing
Section 053100	Steel Decking
<del>Section 054000</del>	<del>Cold Formed Metal Framing</del> (BP1 ADDENDUM NO. 2)
Section 055213	Pipe and Tube Railings
<del>Section 076200</del>	<del>Sheet Metal Flashing and Trim</del>
<del>Section 071100</del>	<del>Roof Specialties</del>
<del>Section 077200</del>	<del>Roof Accessories</del>
Section 079200	Joint Sealants
Section 083323	Overhead Coiling Doors
Section 116143	Stage Curtains
Section 116623	Gymnasium Equipment

This contract also includes, but is not necessarily limited to, all labor, materials and equipment for the following:

1. Provide structural steel, joists and metal floor and roof decking.
2. Furnish anchor bolts and leveling plates to the Concrete Contractor for placement in concrete piers. This Contractor shall coordinate installation with Concrete Contractor prior to steel fabrication and installation.
3. Field check all anchor bolts prior to beginning erection.
4. Roof sump pans and related work.
5. Framing out for openings (roof drains, mechanical openings, access hatches, skylight, stairs, etc.). Assume opening frames will be field installed. This Contractor shall be responsible for coordination and cutting penetrations in roof deck. (BP1 ADDENDUM NO. 2)
6. Prime paint systems, galvanizing, and related finishing of steel items, including shop and field touch up.
7. Masonry or precast anchors welded to steel columns and beams.
8. Supply and install shear studs.

9. Conditions that require in field welding and assembly are the responsibility of this Contractor. Field coordination with the masonry installer will be this Contractor's responsibility. This Contractor shall fabricate, weld and install all reinforcing anchors that connect the structural steel to the masonry systems. Provide all shop fabrication, a field installation and field welding regardless of the weld symbols.
10. All steel testing will be the responsibility of the Construction Manager, however, this Contractor will cooperate with the testing agency in the inspection at the fabrication shop and in the field.
11. Layout, installation and alignment of attachments at the slab edge condition.
12. No electrical power for welders will be provided.
13. Provide data and submittal information related to the Scope of this Contract signed and sealed by a Professional Engineer as required by the Contract Documents, including but not limited to delegated design requirements in specifications.
14. This Contractor shall include all necessary staging, rigging, matting and remobilizations to accommodate this erection sequence.
15. Provide handrails, railings, steel ladders and accessories.
16. Furnish loose steel lintels, angles, plates and embedded items to the Concrete and Masonry contractors.
17. Provide miscellaneous rough hardware, iron shapes, framing and support angles.
18. Provide pipe bollards for installation by Sitework Contractor
19. Provide gratings.
20. Provide louvers and grilles. Coordinate with the Mechanical & Plumbing **and Masonry Contractor. (BP1 ADDENDUM NO. 2)**
21. Provide overhead door frames **and all additional supports. (BP1 ADDENDUM NO. 2)**
22. Provide toilet partition reinforcement/supports (excludes manufacturer's hardware).
23. Provide galvanizing, as required.
24. Provide anchoring devices, fasteners, inserts and other related items associated with the installation of the scope in this contract.
25. Verify field dimensions.



26. All costs for barricades, arrows, pedestrian protections, flag men, etc. will be part of this Contract. It shall be assumed there is at least 1 marked flagger to escort trucks through the project site.
27. Provide daily fine cleanup of the work is the responsibility of each individual Contractor which includes broom cleaning of their debris as required. Daily Fine clean up, on a daily basis, shall be defined as those means/methods utilized to perform the daily cleaning tasks without producing dust, noise and stacking of stored materials. Furnish fine clean up on a daily basis. All debris must be removed from the work area at the end of each work day to the appropriate dumpster.
28. Provide at least a 48 hour notice prior to any delivery. All deliveries are to be between 7:00 AM and 3:30 PM.
29. This is not a secure site. All contractors are responsible for concealing, locking and/or removing any materials on a daily basis. ASD and EDiS will not be responsible for any lost tools, materials or equipment.
30. Provide a \$15,000 allowance, included in base bid, to be used at the discretion of the Construction Manager.
31. **The Demolition Contractor shall coordinate layout and extent of demolition at the roof assembly type RA-09 with Carpentry and General Works Contractor and Structural Steel Contractor—Demolition layout in these locations will be provided by the Carpentry and General Works Contractor. (BP1 ADDENDUM NO. 2)**

CONTRACT NO. A-06 - CARPENTRY AND GENERAL WORK

A. Work included in this contract consists of, but is not necessarily limited to, all labor, materials and equipment for:

- Technical Specification Sections:

Division 0	Bidding and Contract Requirements
Division 1	General Requirements
Section 061000	Rough Carpentry
Section 061600	Sheathing
Section 062023	Interior Finish Carpentry
Section 064023	Interior Architectural Woodwork
Section 078413	Penetration Firestopping
Section 079200	Joint Sealants
Section 081113	Hollow Metal Doors and Frames
Section 081416	Flush Wood Doors
Section 081613	FRP Flush Doors
Section 083323	Overhead Coiling Doors
Section 087100	Door Hardware
Section 101100	Visual Display Units
Section 101416	Plaques
Section 101423	Panel Signage
Section 102123	Cubicle Curtains and Track
Section 102800	Toilet, Bath, and Laundry Accessories
Section 104413	Fire Protection Cabinets
Section 104416	Fire Extinguishers
Section 105113	Metal Lockers
Section 110000	Miscellaneous Equipment
Section 115213	Projection Screens
Section 116143	Stage Curtains
Section 116623	Gymnasium Equipment
Section 122413	Roller Shades
Section 144200	Wheel Chair Lifts

This contract also includes, but is not necessarily limited to, all labor, materials and equipment for the following:

1. Provide labor and materials to perform the work related to all carpentry and general work.
2. Provide all rough carpentry related to the exterior skin of the building including wood nailers, ~~sheeting~~ **sheathing** and blocking. Include all fire treating or exterior grade materials as required. **This shall include new plywood roof deck, high performance underlayment, and ice protection membrane where required. (BP1 ADDENDUM NO.**

- 2)
3. Provide all rough carpentry related to the interior of the building including blocking, sheathing, wood nailers, etc. for the installation of fire extinguishers, doors, door stops, hold opens, instructions boards, tack boards, brackets, lockers, railings, windows, signage, stage **equipment**, ~~or~~ gymnasium equipment, window shades, toilet accessories, cabinets, toilet partitions, casework, millwork, etc. including fire treating, as required. **(BP1 ADDENDUM NO. 2)**
  4. Roof curbs, pipe, hoods and vent equipment & supports are to be supplied by contractor in which the units, piping, etc. are being supplied. The openings for the curbs in the roofing materials shall be cut by the Roofing Contractor. Openings in the metal deck shall be cut by the contractor in which the units are being provided. The roofing contractor shall provide all flashing and sealing of the curbs. Any wood blocking required will be provided by Carpentry & General Works Contractor. **Provide the appropriate thickness of blocking needed to accommodate the roof insulation. The thickness of blocking shown on the Drawings is diagrammatic in nature. (BP1 ADDENDUM NO. 2)**
  5. Provide hollow metal, steel and wood doors, frames, vision panels, and finish hardware, including receipt of doors and frames at the curb side.
  6. Provide hardware for all doors. (Aluminum, FRP, hollow metal, steel and wood) The aluminum and FRP doors will be provided by the Glass & Glazing Contractor. Install finish hardware at all **hollow metal, steel and wood** doors. ~~All low voltage wiring within the wood, steel and hollow metal doors and frames is to be installed by this contractor. All low voltage wiring within the Aluminum & FRP doors and frames is to be installed by the Glass & Glazing contractor. Final connection and power supply to be provided by Electrical Contractor. Attend Hardware Coordination Meetings with security contractor, electrical contractor and owner in order to insure complete system is being provided.~~ **(BP1 ADDENDUM NO. 2)**
  7. All door, frame & hardware materials provided by this Contractor are to be stored by this Contractor until delivery is requested. Material to be delivered within the site and off loaded to hardware room or room to be installed by this contractor. Once on site, this contractor must maintain a door & hardware room on-site that maintains climate requirements. The room security will be this contractor's responsibility.
  8. Provide insulated & non insulated overhead coiling doors. Overhead door frames will be provided **and installed** by the Structural Steel Contractor ~~and installed by this Contractor~~. Coordinate with Structural Steel Contractor who will install additional supports for overhead coiling doors, if required; coordinate with structural drawings. **(BP1 ADDENDUM NO. 2)**
  9. Hardware for permanent exterior gates will be provided by the Sitework Contractor and installed by Carpentry & General Works Contractor. Access control hardware/software and fire alarm integrations of gate hardware, including terminations, cabling, etc. will be

provided by the Special Systems Contractor. The Electrical Contractors shall provide all pathways & electrical requirements to support installation.

10. Coordinate electrical requirements with any automatic door operations, magnetic hold opens or card readers.
11. The contractor responsible for supplying the doors, frames, and hardware shall provide all wiring and accessories from the power supply (**or junction box**) to the door hardware. The contractor responsible for installation of doors and hardware shall provide terminations from door hardware to door whip, from door whip to power transfer, and from frame whip to power transfer. Frame whip shall be secured and protected by the door, frame, and hardware contractor(s) for the direct access of the Special Systems Contractor. Termination of the frame whip to the power supply (**or junction box**) shall be provided by the Special Systems Contractor. Power supply shall be furnished by the door, frame, and hardware contractor(s) and installed by the Special Systems Contractor. The Special Systems Contractor shall provide low-voltage wire from the card reader to the access controller, from the status switch (door contact) to the access controller, from access controller to the power supply (**or junction box**), and from power supply (**or junction box**) to power supply as necessary. The Electrical Contractor is responsible for providing 120v circuits to all power supplies and/or transformers as indicated in the documents. The Electrical Contractor shall provide conduits, device boxes, raceways, and pull strings for low-voltage wiring at doors receiving electronic, security, or access control hardware. Electrical contractor shall provide a junction box above each door scheduled to receive a card reader and a pathway & pull string. A mock-up shall be field installed and coordinated by all related Contractors for review prior to commencing work. **(BP1 ADDENDUM NO. 2)**
12. Provide all keying for all doors. All lock sets (Hollow Metal, Wood Doors, Aluminum Entrances). Provide Owner with copy of pin schedule.
13. **Provide** Construction cylinders. **(BP1 ADDENDUM NO. 2)**
14. Provide electrified hold open hardware with fire alarm interface. Power circuits for devices by Electrical Contractor. Fire alarm wiring, terminations, and programming by Special Systems Contractor. Special Systems Contractor shall provide low-voltage power to door hold open hardware.
- ~~15. Do not include aluminum entrance. Keying for aluminum entrances not confirmed by Construction Manager. (BP1 ADDENDUM NO. 2)~~
16. This contractor is responsible for all field measurements required to retrofit frames and/or doors in existing openings and/or existing wall assemblies.
17. Provide all field trimming required to adjust to existing conditions, **including all interior standing and running trim. (BP1 ADDENDUM NO. 2)**

18. Provide marker and tack boards **and visual display units. (BP1 ADDENDUM NO. 2)**
19. Provide projection screens.
20. Provide signage **and plaques. (BP1 ADDENDUM NO. 2)**
21. Provide lockers.
22. Provide toilet partitions, hardware, and accessories.
23. Provide fire extinguishers, cabinets and accessories.
24. Provide toilet and bath accessories.
25. Provide window treatments **and roller shades. (BP1 ADDENDUM NO. 2)**
26. Provide mirrors.
- ~~27. Provide Wall and corner guards. (BP1 ADDENDUM NO. 2)~~
- ~~28. Provide Display cases. (BP1 ADDENDUM NO. 2)~~
- ~~29. Provide wood stairs to stage. (BP1 ADDENDUM NO. 2)~~
30. Provide Anchoring devices, fasteners, inserts and other related items associated with the installation of the above items.
31. This Contractor shall at a minimum provide and maintain for the length of the project, one temporary fire extinguisher for each 3,000 sq. ft of the protected building area. Fire extinguishers shall be 10lb, Multi-Purpose (ABC) dry chemical, UL labeled, with a rating of 3a:40bc.
32. All material to be stored by this Contractor until delivery is requested. Material to be delivered to the site and off loaded by others.
33. Provide coordination to ensure deliveries to correspond to the construction schedule.
34. Provide field assistance to Electrical and Carpentry Contractors.
35. Smart TVs/displays, projectors, and mounting brackets will be supplied by Owner and mounted by the Carpentry & General Works Contractor. This contractor will coordinate blocking with mounting hardware and install all necessary clips and blocking to the wall for hanging. Audio/visual interface and/or controls by Special Systems Contractor.
36. Provide fire-rated plywood and required coatings in all MDF/IDF rooms, as required.

37. Provide all temporary barricades at all openings in floors, staircases and duct chases and maintain throughout completion of project. Include removal and disposal at completion of project. Protection, at a minimum will consist of (3) 2 x 4 rails and 1/2" plywood framed at all openings. Rails shall be at top, middle and toe boards to meet or exceed OSHA requirements.
38. All costs for barricades, arrows, pedestrian protections, flag men, etc. will be part of this Contract. It shall be assumed there is at least 1 marked flagger to escort trucks through the project site.
39. Provide daily fine cleanup of the work is the responsibility of each individual Contractor which includes broom cleaning of their debris as required. Daily Fine clean up, on a daily basis, shall be defined as those means/methods utilized to perform the daily cleaning tasks without producing dust, noise and stacking of stored materials. Furnish fine clean up on a daily basis. All debris must be removed from the work area at the end of each work day to the appropriate dumpster.
40. Provide at least a 48 hour notice prior to any delivery. All deliveries are to be between 7:00 AM and 3:30 PM.
41. This is not a secure site. All contractors are responsible for concealing, locking and/or removing any materials on a daily basis. ASD and EDiS will not be responsible for any lost tools, materials or equipment.
42. Provide a \$30,000 allowance, included in base bid, to be used at the discretion of the Construction Manager.
43. **Provide Cubicle Curtains and Tracks. (BP1 ADDENDUM NO. 2)**
44. **Provide Miscellaneous Equipment: (BP1 ADDENDUM NO. 2)**
  - a. **Emergency Defibrillator (AED) Cabinets**
  - b. **High Security Knox box**
45. **Provide Stage Curtains. (BP1 ADDENDUM NO. 2)**
46. **Provide Gymnasium Equipment. (BP1 ADDENDUM NO. 2)**
47. **Provide Wheel Chair Lift(s). (BP1 ADDENDUM NO. 2)**
48. **The Demolition Contractor shall coordinate layout and extent of demolition at the roof assembly type RA-09 with Carpentry and General Works Contractor and Structural Steel Contractor—demolition layout in these locations will be provided by the Carpentry and General Works Contractor. (BP1 ADDENDUM NO. 2)**

CONTRACT NO. A-07 - ROOFING

A. Work included in this contract consists of, but is not necessarily limited to, all labor, materials and equipment for:

- Technical Specification Sections:

Division 0	Bidding and Contract Requirements
Division 1	General Requirements
<del>Section 061600</del>	<del>Sheathing</del> (BP1 ADDENDUM NO. 2)
Section 072200	Ventilated Roof Insulation Panels
Section 073113	Asphalt Shingles
Section 075300	EPDM Thermoset Single-ply Roofing
Section 076200	Sheet Metal Flashing and Trim
Section 071100	Roof Specialties
Section 077200	Roof Accessories
Section 079200	Joint Sealants

This contract also includes, but is not necessarily limited to, all labor, materials and equipment for the following:

1. Provide all roofing, including accessories for a complete and watertight installation. System shall include, but not be limited to: tapered insulation, PVC materials, adhesives and fasteners, sealants, insulation (including design), flashings, cants, copings, reglets and counter flashings, roof-edge specialties, crickets, walkway pads, downspouts, lamb tongue, mechanical & plumbing penetrations, roof overflow drains , temporary openings at all penetrations and temporary and permanent flashing at all mechanical equipment curbs.
2. Provide elastomeric membrane roofing system (EPDM), including rigid and tapered insulation and all related accessories.
3. Provide asphalt shingle roofing system, including **composite roof** insulation **panels** and all related accessories. (BP1 ADDENDUM NO. 2)
4. This contractor shall carefully review the edge of roof details to determine if the roof can be placed before the exterior wall assembly is complete. This contractor shall include all costs associated with returning to the jobsite to complete the roof perimeter after wall assembly is complete.
5. Provide caulking related to roofing, flashing and roof accessories.
6. The roof drains and associated plumbing shall be provided by the Mechanical Contractor. Flashing of the roof drains shall be by the Roofing Contractor. Openings for the roof drains in the roofing materials shall be cut by the Roofing Contractor. Openings in the metal deck shall be cut by others.

7. Provide all metal parapet coping, fasteners, & sealants.
8. Provide walk pads (Traffic Pads).
9. Perform cutting, patching and maintenance of temporary patch for work performed by others on existing roofs intended to be re-roofed as part of this work.
10. Provide metal drip edges.
11. Roof curbs, pipe, hoods and vent equipment & supports are to be supplied by contractor in which the units, piping, etc. are being supplied. The openings for the curbs in the roofing materials shall be cut by the Roofing Contractor. Openings in the metal deck shall be cut by the contractor in which the units are being provided. The roofing contractor shall provide all flashing and sealing of the curbs. Any wood blocking required will be provided by Carpentry & General Works Contractor.
12. Provide expansion joints and associated insulation that are integral to the roof.
13. Provide permanent patching of existing roofing systems at areas of demolition. Demolition of roof drains, mechanical and electrical equipment shall be performed by others. All patching shall conform to original warranty requirements and documents.
14. Provide gutters, downspouts and splash pans/blocks.
15. Wood blocking shall be provided by Carpentry & General Works Contractor.
16. Provide all flashing, copings, roof edge components, base flashing, sealing, and insulation around floor curbs, parapets, pitch pockets, vents, stacks, drains, roof hatches, ducts, and other structural, architectural, mechanical, and electrical penetrations in the roof to form a watertight roofing system as indicated. Provide all counter flashing to roof and to walls.
17. Flashing Summary:
  - a. Thru wall and cavity flashing below the **relative** roof line shall be provided by the Masonry Contractor. **(BP1 ADDENDUM NO. 2)**
  - b. Thru wall and cavity flashing above the **relative** roof line shall be provided by the Roofing Contractor. **(BP1 ADDENDUM NO. 2)**
18. Provide all cranes, scaffolding and lifts for this work.
- ~~19. Delegated design of roof curbs and roof mounted equipment supports, refer to specification Section 077200 – Roofing Accessories. (BP1 ADDENDUM NO. 2)~~
20. All costs for barricades, arrows, pedestrian protections, flag men, etc. will be part of this Contract. It shall be assumed there is at least 1 marked flagger to escort trucks through the project site.



21. Provide daily fine cleanup of the work is the responsibility of each individual Contractor which includes broom cleaning of their debris as required. Daily Fine clean up, on a daily basis, shall be defined as those means/methods utilized to perform the daily cleaning tasks without producing dust, noise and stacking of stored materials. Furnish fine clean up on a daily basis. All debris must be removed from the work area at the end of each work day to the appropriate dumpster.
22. Provide at least a 48 hour notice prior to any delivery. All deliveries are to be between 7:00 AM and 3:30 PM.
23. This is not a secure site. All contractors are responsible for concealing, locking and/or removing any materials on a daily basis. ASD and EDiS will not be responsible for any lost tools, materials or equipment.
24. Provide a \$20,000 allowance, included in base bid, to be used at the discretion of the Construction Manager.
25. **The Demolition Contractor will be responsible for complete demolition of the roofing systems in all locations where existing roof deck is removed. The Demolition Contractor shall coordinate layout and extent of demolition at the roof assembly type RA-09 with Carpentry and General Works Contractor and Structural Steel Contractor—Demolition layout in these locations will be provided by the Carpentry and General Works Contractor. The Roofing Contractor will be responsible for complete demolition of roofing systems in all locations where existing roof deck will remain. (BP1 ADDENDUM NO. 2)**

CONTRACT NO. A-08 – METAL STUDS & DRYWALL

A. Work included in this contract consists of, but is not necessarily limited to, all labor, materials and equipment for:

- Technical Specification Sections:

Division 0	Bidding and Contract Requirements
Division 1	General Requirements
<del>Section 05120</del>	<del>Structural Steel (BP1 ADDENDUM NO. 2)</del>
Section 054000	Cold-Formed Metal Framing
Section 061600	Sheathing
Section 072100	Thermal Insulation
<del>Section 072119</del>	<del>Foamed In-Place Insulation (BP1 ADDENDUM NO. 2)</del>
Section 074646	Fiber-Cement Siding
<del>Section 078413</del>	<del>Penetration Firestopping (BP1 ADDENDUM NO. 2)</del>
Section 079100	Preformed Joint Seals
Section 079200	Joint Sealants
Section 079513.13	Interior Joint Cover Assemblies
Section 081113	Hollow Metal Doors and Frames
Section 083113	Access Doors and Frames
<b>Section 093000</b>	<b>Tiling (BP1 ADDENDUM NO. 2)</b>
<b>Section 097720</b>	<b>Fiberglass Reinforced Wall Panel (BP1 ADDENDUM NO. 2)</b>
Section 102600	Wall and Corner Protection

This contract also includes, but is not necessarily limited to, all labor, materials and equipment for the following:

1. Provide structural stud assembly for the exterior envelope construction.
- ~~2. Provide steel stud construction related to the roof details at dormers. (BP1 ADDENDUM NO. 2)~~
3. Provide steel stud construction related to framing out for openings in interior and exterior walls.
4. Provide secondary support framing.
5. Provide clips, anchors, supports and other accessories that interface between steel framing and steel studding.
6. Provide metal studs, insulation, gypsum wallboard, taping, and spackling.
7. Provide tile backing board for ceramic tile. All walls shall meet or exceed NTCA tolerances for ceramic tile installations. Any additional reworking required to meet these tolerances will be this contractor's responsibility in cost and schedule.

8. Provide all metal stud framing required to back up Manufactured Molding and Trim, cementitious siding, brick, etc.
9. Provide metal furring.
10. Provide all glass fiber reinforced gypsum work including materials, taping.
11. Provide batt insulation, both thermal and acoustical and related work.
12. Include molded shapes.
13. Provide acoustical sealant of **top and bottom of drywall partitions and in** penetrations in insulated **and non/insulated** drywall partitions. **This shall include steel penetrations through wall assemblies—provide fire stopping and fire containment sealant in rated drywall partitions. (BP1 ADDENDUM NO. 2)**
14. Provide installation of access doors & frames in both masonry & drywall walls. Access doors and frames provided by other contracts (Kitchen Equipment, Fire Protection, Mechanical & Plumbing, Building Management Systems, Special Systems, & Structured Cable)—assume 30 total.
15. Coordinate filling of all interior hollow metal door frames in drywall where required.
16. Include fire taping and sealing at perimeter edge and as shown on the Drawings.
17. Provide architectural expansion joint systems **for metal stud and drywall systems, floor systems, and ceilings**, including joint covers materials at concrete slab, drywall and masonry construction (interior only). **This Contractor must coordinate the installation to ensure layout is consistent with wall installation. This Contractor shall be responsible for all control joints required for work completed under this contract. (BP1 ADDENDUM NO. 2)**
18. Provide all cranes, scaffolding and lifts for this work.
19. Comebacks and out-of-sequence work may be required and as such should be included.
20. Include all necessary field measurements.
21. Engineered shop and installation drawings as required.
22. Provide all exterior wall sheathing (~~DensGlass, flashings, etc.~~), ~~asphalt felts and Tyvek~~ on structural steel studs. **Provide insulation, air barrier, vapor/moisture barrier, where required (at locations not receiving spray foam insulation). (BP1 ADDENDUM NO. 2)**
23. Provide **fiber-cement** ~~cementitious~~ siding, fascia's, trim pieces, **flashing, accessories**, etc. ~~Confirm nothing else is required here~~ **(BP1 ADDENDUM NO. 2)**

24. Installation of masonry veneer anchors are not to be included in this work. They will be provided by the Masonry Contractor.
25. No power for welding equipment will be provided.
26. Provide ~~fire resistant joint systems at floors and walls.~~ **(BP1 ADDENDUM NO. 2)**
27. Include two (2) passes per floor to “touch-up” mechanical penetrations to ensure ratings required. The first pass will be required prior to ceiling grid installation and the second pass will be required prior to final inspection for Certificate of Occupancy.
28. Bidders are advised to pay particular attention to top of wall conditions, fire and smoke safing of slabs and acoustical sealants.
29. Provide pricing for all alternates as described in Section 012300-Alternates.
30. Provide all metal framing as indicated for back up of other materials.
31. Coordination and allowing full access to other trades so they can perform their work will be included and part of this Contractor’s obligation. Any unused portion of the allowance will be returned to the Owner.
- ~~32. Inspection of the fireproofing will be the responsibility of the Construction Manager.~~ **(BP1 ADDENDUM NO. 2)**
- ~~33. Protect fireproofing according to advice of fireproofing manufacturer and installer from damage resulting from construction operations or other causes so that fireproofing will be without damage or deterioration at time of Substantial Completion.~~ **(BP1 ADDENDUM NO. 2)**
- ~~34. Coordinate installation of fireproofing with other work in order to minimize the need for other trades to cut or remove fireproofing. As other trades successively complete installation of their work, maintain protection of structure afforded by fireproofing by patching any areas which have been removed or damaged prior to concealment of fireproofing by other work.~~ **(BP1 ADDENDUM NO. 2)**
- ~~35. Repair or replace work which has not been successfully protected.~~ **(BP1 ADDENDUM NO. 2)**
- ~~36. Prepare all surfaces including priming substrate, if needed.~~ **(BP1 ADDENDUM NO. 2)**
- ~~37. Provide all required steel frame fireproofing whether clearly shown or not on the drawings. Do not include concrete fire proofing.~~ **(BP1 ADDENDUM NO. 2)**
38. Provide Exterior Cellular PVC ~~Manufactured~~ Molding and Trim. ~~Exterior metal studding, insulation, gypsum board and Tyvek will be provided by Contract A-07.~~ **(BP1 ADDENDUM NO. 2)**
  - a. Provide Exterior Cellular PVC ~~Manufactured~~ Molding and Trim as field applied or

panelized.

i. Provide caulking of the following:

1. Exterior Cellular PVC ~~Manufactured~~ Molding and Trim to Exterior Cellular PVC ~~Manufactured~~ Molding and Trim
2. Exterior Cellular PVC ~~Manufactured~~ Molding and Trim to Masonry
3. Exterior Cellular PVC ~~Manufactured~~ Molding and Trim to Aluminum

- b. Provide flashing required at Exterior Cellular PVC ~~Manufactured~~ Molding and Trim.
- c. Provide any rough blocking built into Exterior Cellular PVC ~~Manufactured~~ Molding and Trim is the responsibility of this Contractor.
- d. Provide hoisting and scaffolding as required.
- e. Provide anchors for supporting Exterior Cellular PVC ~~Manufactured~~ Molding and Trim.
- f. Provide scoring, beads and joints as required and as detailed on the contract documents.

~~39. Provide fireproofing, both exposed and concealed. (BP1 ADDENDUM NO. 2)~~

- ~~a. Provide clean up on a daily basis, all over spray materials. Provide perimeter protection around areas of fireproofing installation to protect surrounding materials and public properties. Any damages caused by overspray of fireproofing materials will be repaired and compensated for by this contractor.~~
- ~~b. Inspection of the fireproofing will be the responsibility of the Construction Manager.~~
- ~~c. Protect fireproofing according to advice of fireproofing manufacturer and installer from damage resulting from construction operations or other causes so that fireproofing will be without damage or deterioration at time of Substantial Completion.~~
- ~~d. Coordinate installation of fireproofing with other work in order to minimize the need for other trades to cut or remove fireproofing. As other trades successively complete installation of their work, maintain protection of structure afforded by fireproofing by patching any areas which have been removed or damaged prior to concealment of fireproofing by other work.~~
- ~~e. Repair or replace work which has not been successfully protected.~~
- ~~f. Prepare all surfaces including priming substrate, if needed.~~
- ~~g. Provide all required steel frame fireproofing whether clearly shown or not on the drawings. Do not include concrete fire proofing.~~

~~40. Expansion joints integral to the metal stud & drywall systems will be provided by Carpentry & General Works contractor. This Contractor must coordinate the installation to ensure layout is consistent with wall installation. This Contractor shall be responsible for all control joints required for work completed under this contract. (BP1 ADDENDUM NO. 2)~~

41. Provide data and submittal information related to the Scope of this Contract signed and sealed by a Professional Engineer as required by the Contract Documents, including but not limited to delegated design requirements in specifications.

42. All costs for barricades, arrows, pedestrian protections, flag men, etc. will be part of this Contract. It shall be assumed there is at least 1 marked flagger to escort trucks through the project site.

43. Provide daily fine cleanup of the work is the responsibility of each individual Contractor which

includes broom cleaning of their debris as required. Daily Fine clean up, on a daily basis, shall be defined as those means/methods utilized to perform the daily cleaning tasks without producing dust, noise and stacking of stored materials. Furnish fine clean up on a daily basis. All debris must be removed from the work area at the end of each work day to the appropriate dumpster.

44. Provide at least a 48 hour notice prior to any delivery. All deliveries are to be between 7:00 AM and 3:30 PM.
45. This is not a secure site. All contractors are responsible for concealing, locking and/or removing any materials on a daily basis. ASD and EDiS will not be responsible for any lost tools, materials or equipment.
46. Provide a \$20,000 allowance to be used at the discretion of the Construction Manager.
47. **Provide Wall and corner guards. (BP1 ADDENDUM NO. 2)**
48. **Casework and Millwork Contractor shall provide stage stair stringers, stair risers & treads, stage front (including wood base, paneling, stage fascia, stage nosing, and all wood trim). Stage wood flooring by Flooring Contractor, and terminates at stage nosing and top stair tread. Stage and knee-wall framing at stage by Metal Stud & Drywall Contractor. Proscenium framing and FRP enclosure by Metal Stud & Drywall Contractor. (BP1 ADDENDUM NO. 2)**
49. **Provide Fiberglass Reinforced Wall Panels. (BP1 ADDENDUM NO. 2)**

CONTRACT NO. A-09 – GLASS & GLAZING

A. Work included in this contract consists of, but is not necessarily limited to, all labor, materials and equipment for:

- Technical Specification Sections:

Division 0	Bidding and Contract Requirements
Division 1	General Requirements
Section 079200	Joint Sealants
Section 081613	FRP Flush Doors
Section 084113	Aluminum-Framed Entrances and Storefronts
Section 085113	Aluminum Windows
Section 087100	Door Hardware
Section 088000	Glazing

This contract also includes, but is not necessarily limited to, all labor, materials and equipment for the following:

1. Provide all storefront and all glass and glazing systems.
2. Provide manual aluminum door systems and handling.
3. Provide automatic aluminum door systems, including hardware.
4. Provide doors and frames for all aluminum and FRP doors. The hollow metal, steel and wood doors will be provided by the Carpentry & General Works Contractor.
5. Install finish hardware for aluminum and FRP doors only. Hardware for all FRP & aluminum doors will be supplied by Contract A-06, Carpentry & General Works and installed by this subcontractor.
6. The contractor responsible for supplying the doors, frames, and hardware shall provide all wiring and accessories from the power supply (**or junction box**) to the door hardware. The contractor responsible for installation of doors and hardware shall provide terminations from door hardware to door whip, from door whip to power transfer, and from frame whip to power transfer. Frame whip shall be secured and protected by the door, frame, and hardware contractor(s) for the direct access of the Special Systems Contractor. Termination of the frame whip to the power supply (**or junction box**) shall be provided by the Special Systems Contractor. Power supply shall be furnished by the door, frame, and hardware contractor(s) and installed by the Special Systems Contractor. The Special Systems Contractor shall provide low-voltage wire from the card reader to the access controller, from the status switch (door contact) to the access controller, from access controller to the power supply (**or junction box**), and from power supply (**or junction box**) to power supply (**or junction box**) as necessary. The Electrical Contractor is responsible for providing 120v circuits to all power supplies and/or transformers as indicated in the

documents. The Electrical Contractor shall provide conduits, device boxes, raceways, and pull strings for low-voltage wiring at doors receiving electronic, security, or access control hardware. Electrical contractor shall provide a junction box above each door scheduled to receive a card reader and a pathway & pull string. A mock-up shall be field installed and coordinated by all related Contractors for review prior to commencing work. **(BP1 ADDENDUM NO. 2)**

7. Provide all glass and glazing at exterior of building.
8. Provide all interior glass and glazing systems.
9. Coordinate glass types with partition and door fire ratings. Contact Construction Manager with any discrepancies.
10. Provide caulking related to all glass. This includes all interior and exterior glass systems.
11. Provide caulk between the materials supplied under this section and the adjacent surfaces.
12. Provide mock-ups as required by the Drawings and Specifications.
13. Provide custom break metal trim and infill.
14. Provide all hoisting/scaffolding related to the work of this Contract.
15. Coordinate edge of slab tolerances and field verify all rough openings.
16. Provide pricing for all alternates as described in Section 012300-Alternates.
17. All door, frame & hardware materials provided by this Contractor are to be stored by this Contractor until delivery is requested. Material to be delivered within the site and off loaded by this contractor. Once on site, this contractor must maintain a door & hardware room on-site. The room security will be this contractor's responsibility. **(BP1 ADDENDUM NO. 2)**
18. Provide data and submittal information related to the Scope of this Contract signed and sealed by a Professional Engineer as required by the Contract Documents, including but not limited to delegated design requirements in specifications.
19. All costs for barricades, arrows, pedestrian protections, flag men, etc. will be part of this Contract. It shall be assumed there is at least 1 marked flagger to escort trucks through the project site.
20. Provide daily fine cleanup of the work is the responsibility of each individual Contractor which includes broom cleaning of their debris as required. Daily Fine clean up, on a daily basis, shall be defined as those means/methods utilized to perform the daily cleaning tasks without producing dust, noise and stacking of stored materials. Furnish fine clean up on a



daily basis. All debris must be removed from the work area at the end of each work day to the appropriate dumpster.

21. Provide at least a 48 hour notice prior to any delivery. All deliveries are to be between 7:00 AM and 3:30 PM.
22. This is not a secure site. All contractors are responsible for concealing, locking and/or removing any materials on a daily basis. ASD and EDiS will not be responsible for any lost tools, materials or equipment.
23. Provide a \$5,000 allowance, included in base bid, to be used at the discretion of the Construction Manager.

CONTRACT NO. A-10 - CASEWORK AND MILLWORK

A. Work included in this contract consists of, but is not necessarily limited to, all labor, materials and equipment for:

- Technical Specification sections:

Division 0	Bidding and Contract Requirements
Division 1	General Requirements
Section 062023	Interior Finish Carpentry
Section 064023	Interior Architectural Woodwork
Section 079200	Joint Sealants
Section 123200	Modular Casework

This contract also includes, but is not necessarily limited to, all labor, materials and equipment for the following:

1. Provide labor and materials to perform the work related to all casework and millwork.
2. Provide all field trimming required to adjust to existing conditions.
3. Provide all millwork, casework, trim and hardware and including all toe kicks, student cubbies, shelves, enclosures at lockers, filler strips and window stools **and window aprons, where were** indicated in the project document. **(BP1 ADDENDUM NO. 2)**
4. Provide all wardrobe and closet specialties such as hardware, hooks, shelves, etc.
5. Coordinate power and data requirements and locations with the electrical contractor for locations and sizes of holes needed.
- ~~6. Comply with AWI quality certifications. (BP1 ADDENDUM NO. 2)~~
7. Provide countertops, filler strips and backsplashes were indicated in the project documents.
8. Coordinate and cutting holes in casework and/or countertop with other trades. **This Contractor shall cut holes in countertops and casework as required for all trades. (BP1 ADDENDUM NO. 2)**
9. Coordinate blocking requirements with Contract A-05: Carpentry & General Works.
10. Provide caulking and joint sealers integral to casework/millwork/countertops and to dissimilar materials.
11. Provide pricing for all alternates as described in Section 012300-Alternates.
12. Provide all keying to all cabinets as specified.

13. Provide main office desk **and** media center circulation desk, ~~stage front, proscenium opening. Stairs to stage provided by Carpentry & General Work Contractor.~~ (BP1 ADDENDUM NO. 2)
14. Provide specified warranties.
15. Provide mockups as specified.
16. All costs for barricades, arrows, pedestrian protections, flag men, etc. will be part of this Contract. It shall be assumed there is at least 1 marked flagger to escort trucks through the project site.
17. Provide daily fine cleanup of the work is the responsibility of each individual Contractor which includes broom cleaning of their debris as required. Daily Fine clean up, on a daily basis, shall be defined as those means/methods utilized to perform the daily cleaning tasks without producing dust, noise and stacking of stored materials. Furnish fine clean up on a daily basis. All debris must be removed from the work area at the end of each work day to the appropriate dumpster.
18. Provide at least a 48 hour notice prior to any delivery. All deliveries are to be between 7:00 AM and 3:30 PM.
19. This is not a secure site. All contractors are responsible for concealing, locking and/or removing any materials on a daily basis. ASD and EDiS will not be responsible for any lost tools, materials or equipment.
20. Provide a \$5,000 allowance, included in base bid, to be used at the discretion of the Construction Manager.
21. **Casework and Millwork Contractor shall provide stage stair stringers, stair risers & treads, stage front (including wood base, paneling, stage fascia, stage nosing, and all wood trim). Stage wood flooring by Flooring Contractor, and terminates at stage nosing and top stair tread. Stage and knee-wall framing at stage by Metal Stud & Drywall Contractor. Proscenium framing and FRP enclosure by Metal Stud & Drywall Contractor.** (BP1 ADDENDUM NO. 2)

CONTRACT NO. A-11 - FOLDING PANEL PARTITIONS

A. Work included in this contract consists of, but is not necessarily limited to, all labor, materials and equipment for:

- Technical Specification sections:

Division 0	Bidding and Contract Requirements
Division 1	General Requirements
Section 079200	Joint Sealants
Section 102239	Folding Panel Partitions
Division 26	Electrical

This contract also includes, but is not necessarily limited to, all labor, materials and equipment for the following:

1. Provide labor and materials to perform the work related to all work associated with completing Folding Panel Partitions.
2. Provide all field trimming required to adjust to existing conditions.
3. Provide coordinated shop drawings that reflect all structural requirements with the structural steel, metal studs, ceilings, electrical power, lighting and communication systems, etc.
4. Provide all trim components, hardware, hinges, operators for electrical units, appropriate finishes, sensors, key switches and pocket doors for concealing doors when not in use.
5. Electrical connections will be provided by Electrical Contractor. This contractor shall provide assistance to Electrical Contractor for coordination and installation of necessary connections.
6. Provide any required signage for safe operations
7. Provide attic stock, warranty and demonstrations for all materials and types of panels.
8. Provide specified testing, adjusting, warranty and training demonstrations on the operation.
9. Provide pricing for all alternates as described in Section 012300-Alternates.
10. Coordinate supplementary steel as needed to hang partitions from structural support steel, provided by the Structural Steel Contractor, as shown in partition details on Drawing A50.9. It is assumed, no additional steel will be required below structural support steel. If so, it will be provided by this contractor.
11. Provide data and submittal information related to the Scope of this Contract signed and sealed by a Professional Engineer as required by the Contract Documents, including but not

limited to delegated design requirements in specifications.

12. All costs for barricades, arrows, pedestrian protections, flag men, etc. will be part of this Contract. It shall be assumed there is at least 1 marked flagger to escort trucks through the project site.
13. Provide daily fine cleanup of the work is the responsibility of each individual Contractor which includes broom cleaning of their debris as required. Daily Fine clean up, on a daily basis, shall be defined as those means/methods utilized to perform the daily cleaning tasks without producing dust, noise and stacking of stored materials. Furnish fine clean up on a daily basis. All debris must be removed from the work area at the end of each work day to the appropriate dumpster.
14. Provide at least a 48 hour notice prior to any delivery. All deliveries are to be between 7:00 AM and 3:30 PM.
15. This is not a secure site. All contractors are responsible for concealing, locking and/or removing any materials on a daily basis. ASD and EDiS will not be responsible for any lost tools, materials or equipment.

CONTRACT NO. A-12 - PAINTING

A. Work included in this contract consists of, but is not necessarily limited to, all labor, materials and equipment for:

- Technical Specification Sections:

Division 0	Bidding and Contract Requirements
Division 1	General Requirements
Section 079200	Joint Sealants
Section 081113	Hollow Metal Doors and Frames
<del>Section 081416</del>	<del>Flush Wood Doors</del> <b>(BP1 ADDENDUM NO. 2)</b>
Section 099100	Painting

This contract also includes, but is not necessarily limited to, all labor, materials and equipment for the following:

1. Provide all painting. (all walls and ceilings indicated on the finish schedule).
2. Sealing all interior joints between dissimilar materials that require sealants.
3. Paint all exposed block work and concrete work as shown on the room finish schedule.
4. Prime, stain or seal all wood trim and doors, where applicable. Paint all hollow metal doors, door frames, and windows, where applicable.
5. Paint exposed piping and ductwork (sprinkler, plumbing, electrical) in accordance with the Drawings and Specifications.
6. Provide supplementary ventilation as required in enclosed spaces.
7. Paint and caulk all hollow metal frames and doors as shown on the door schedule.
8. Paint metal railings.
9. Prefinished items will not be painted by this Contractor.
10. Paint all semi-exposed wood blocking as indicated on the drawing.
11. Protection of adjacent surfaces.
12. Minor patching and preparation prior to application of finishes.
13. ~~This Contractor to allow 200 man hours and all required paint materials for these man hours to be used as directed by the Construction Manager.-(BP1 ADDENDUM NO. 2)~~

14. Provide attic stock.
15. Final coat of paint is to be installed after ceilings are installed, if directed by Construction Manager.
16. All costs for barricades, arrows, pedestrian protections, flag men, etc. will be part of this Contract. It shall be assumed there is at least 1 marked flagger to escort trucks through the project site.
17. Provide daily fine cleanup of the work is the responsibility of each individual Contractor which includes broom cleaning of their debris as required. Daily Fine clean up, on a daily basis, shall be defined as those means/methods utilized to perform the daily cleaning tasks without producing dust, noise and stacking of stored materials. Furnish fine clean up on a daily basis. All debris must be removed from the work area at the end of each work day to the appropriate dumpster.
18. Provide at least a 48 hour notice prior to any delivery. All deliveries are to be between 7:00 AM and 3:30 PM.
19. This is not a secure site. All contractors are responsible for concealing, locking and/or removing any materials on a daily basis. ASD and EDiS will not be responsible for any lost tools, materials or equipment.
20. Provide a \$10,000 allowance, included in base bid, to be used at the discretion of the Construction Manager.

CONTRACT NO. A-13 - ACOUSTICAL CEILINGS

A. Work included in this contract consists of, but is not necessarily limited to, all labor, materials and equipment for:

- Technical Specification Sections:

Division 0	Bidding and Contract Requirements
Division 1	General Requirements
Section 079200	Joint Sealants
Section 095113	Acoustical Panel Ceilings
Section 097723	Fabric-Wrapped Panels

This contract also includes, but is not necessarily limited to, all labor, materials and equipment for the following:

1. Provide acoustical panel ceilings, suspension system and hangers.
2. Provide acoustical lay in insulation blankets above ceiling where required by Specifications or Drawings.
3. Provide supplemental suspension hangers, relative to acoustical ceilings, at large ducts above ceilings and at openings for lighting fixtures. Acoustical ceiling system shall be independently supported.
4. Provide hold down clips as indicated in the construction documents.
5. ~~Provide aluminum pan ceilings. (BP1 ADDENDUM NO. 2)~~
6. Provide expansion joints associated with ceiling system.
7. Provide reflected ceiling layout and coordination with all trades responsible for mounting equipment in or connected to ceiling system. This contractor shall be responsible for field verification of conditions and shall inform the Construction Manager if existing conditions differ from drawings and specifications.
8. Provide joint sealants at wall angles, where required.
9. This Contractor shall cut openings in ceilings for sprinkler heads, lights, electrical devices, mechanical diffusers and grilles, etc.
10. Provide attic stock.
11. Provide acoustical wall treatment (**acoustical wall panels/fabric wrapped panels**) (BP1 ADDENDUM NO. 2).



12. All costs for barricades, arrows, pedestrian protections, flag men, etc. will be part of this Contract. It shall be assumed there is at least 1 marked flagger to escort trucks through the project site.
13. Provide daily fine cleanup of the work is the responsibility of each individual Contractor which includes broom cleaning of their debris as required. Daily Fine clean up, on a daily basis, shall be defined as those means/methods utilized to perform the daily cleaning tasks without producing dust, noise and stacking of stored materials. Furnish fine clean up on a daily basis. All debris must be removed from the work area at the end of each work day to the appropriate dumpster.
14. Provide at least a 48 hour notice prior to any delivery. All deliveries are to be between 7:00 AM and 3:30 PM.
15. This is not a secure site. All contractors are responsible for concealing, locking and/or removing any materials on a daily basis. ASD and EDiS will not be responsible for any lost tools, materials or equipment.
16. Provide a \$5,000 allowance, included in base bid, to be used at the discretion of the Construction Manager.

- ~~1. Provide protection, maintenance and the removal of finished products once accepted by Construction Manager. Protection shall consist of Ram Board or equal flooring protection, secured and covering all areas of wood floor and Masonite over high traffic areas on top of the flooring protection. (If recommended by tile manufacturer, provide coat of protective cleaner to all floors and walls. Do not remove until Construction Manager Direction. Provide cleaning and protection upon completion of rooms or areas.~~

CONTRACT NO. A-14 – FLOORING

A. Work included in this contract consists of, but is not necessarily limited to, all labor, materials and equipment for:

- Technical Specification Sections:

Division 0	Bidding and Contract Requirements
Division 1	General Requirements
Section 078413	Penetration Firestopping
Section 079200	Joint Sealants
Section 096429	Wood Strip Flooring
Section 096500	Resilient Flooring
Section 096513	Resilient Base and Accessories
Section 096516	Resilient Sheet Flooring
Section 096519	Resilient Tile Flooring
Section 096713	Carpet Tile

This contract also includes, but is not necessarily limited to, all labor, materials and equipment for the following:

1. Provide all flooring, with exception of the resinous flooring, in accordance with the finish schedule and specifications. Resinous flooring will be provided by Resinous Flooring contractor.
2. Prepare subfloor for finished flooring including leveling and patching. Base bid shall include all flashing patching and surface preparation required to perform the work of this Contractor. Patching shall include all preparation and finishing at control joints, expansion joints, column diamonds, and flooring type transitions.
3. Provide all resilient flooring, resilient base, thresholds reducer strips, leveling compounds and accessories. This work shall include all flooring (VCT, LVT & vinyl sheet flooring), base, stair treads, moldings, adhesives, fasteners and accessories. Per ASD, the floor polishing of resilient flooring will be completed by ASD. Do NOT include costs in base bid for polishing of these floors.
4. Provide wood flooring, thresholds and all underlayments, including but not limited to: sleepers, vapor barriers, reducer strips and fasteners and leveling compounds. Provide protection of all wood flooring, maintenance of and the removal of products once accepted by Construction Manager. Protection shall consist of Ram Board or equal flooring

- protection, secured and covering all areas of wood floor and Masonite over high traffic areas on top of the flooring protection.
5. Provide all carpeting. Include all patching, adhesives, edge strips, reducer strips, leveling compounds and fasteners.
  6. Provide protection, maintenance and the removal of finished products once accepted by Construction Manager. Protection shall consist of Ram Board or equal flooring protection, secured and covering all areas of wood floor and Masonite over high traffic areas on top of the flooring protection. (If recommended by tile manufacturer, provide coat of protective cleaner to all floors and walls. Do not remove until Construction Manager Direction. Provide cleaning and protection upon completion of rooms or areas.
  7. Provide attic stock of each material as specified.
  8. Provide walk-off carpet tile.
  9. Provide cutting and fitting around work of others.
  10. Provide pricing for all alternates as described in Section 012300-Alternates.
  11. Provide coordinated shop drawing for all flooring materials as indicated in flooring technical specifications.
  12. All ceramic tile will be the responsibility of the ceramic tile contractor. This contractor will only be responsible for modifying work to meet thresholds of ceramic tile installations.
  13. Provide resilient base at all perimeter of all casework, unless noted otherwise.
  14. Provide mock ups as specified.
  15. Provide multiple moisture tests, of all flooring systems, prior to installation.
  16. Provide in base bid all costs for the storage of all material off site until environmental conditions allow for delivery to site and/or delivery is directed by Construction Manager.
  17. All costs for barricades, arrows, pedestrian protections, flag men, etc. will be part of this Contract. It shall be assumed there is at least 1 marked flagger to escort trucks through the project site.
  18. Provide daily fine cleanup of the work is the responsibility of each individual Contractor which includes broom cleaning of their debris as required. Daily Fine clean up, on a daily basis, shall be defined as those means/methods utilized to perform the daily cleaning tasks without producing dust, noise and stacking of stored materials. Furnish fine clean up on a daily basis. All debris must be removed from the work area at the end of each work day to the appropriate dumpster.

19. Provide at least a 48 hour notice prior to any delivery. All deliveries are to be between 7:00 AM and 3:30 PM.
20. This is not a secure site. All contractors are responsible for concealing, locking and/or removing any materials on a daily basis. ASD and EDiS will not be responsible for any lost tools, materials or equipment.
21. Provide a \$10,000 allowance, included in base bid, to be used at the discretion of the Construction Manager.
22. **Casework and Millwork Contractor shall provide stage stair stringers, stair risers & treads, stage front (including wood base, paneling, stage fascia, stage nosing, and all wood trim). Stage wood flooring by Flooring Contractor, and terminates at stage nosing and top stair tread. Stage and knee-wall framing at stage by Metal Stud & Drywall Contractor. Proscenium framing and FRP enclosure by Metal Stud & Drywall Contractor. (BP1 ADDENDUM NO. 2)**
23. Provide safety flooring and base in kitchen walk-in cooler and freezer unit per drawing K-102. (BP1 ADDENDUM NO. 2)
24. Provide a \$15,000 allowance, included in base bid, specific to repair of existing concrete slab to remain prior to installation of new flooring system. Allowance to be used at the discretion of the Construction Manager. (BP1 ADDENDUM NO. 2)

CONTRACT NO. A-15 – RESINOUS FLOORING

A. Work included in this contract consists of, but is not necessarily limited to, all labor, materials and equipment for:

- Technical Specification Sections:

Division 0	Bidding and Contract Requirements
Division 1	General Requirements
Section 078413	Penetration Firestopping
Section 079200	Joint Sealants
Section 096723	Resinous Flooring

This contract also includes, but is not necessarily limited to, all labor, materials and equipment for the following:

1. Provide resinous flooring and flooring sealers in accordance with the finish schedule and specifications.
2. Prepare subfloor for finished flooring including leveling and patching. Base bid shall include all flashing patching and surface preparation required to perform the work of this Contractor.
3. Provide cleaning and protection upon completion of rooms or areas.
4. Coordinate around work of others, including floor drains, cleanouts, etc.
5. Provide pricing for all alternates as described in Section 012300-Alternates.
6. Provide mock ups as specified.
7. Provide multiple moisture tests, of all flooring systems, prior to installation.
8. Provide in base bid all costs for the storage of all material off site until environmental conditions allow for delivery to site and/or delivery is directed by Construction Manager.
9. Provide protection, maintenance and the removal of finished products once accepted by Construction Manager. Protection shall consist of Ram Board or equal flooring protection, secured and covering all areas of wood floor and Masonite over high traffic areas on top of the flooring protection. (If recommended by tile manufacturer, provide coat of protective cleaner to all floors and walls. Do not remove until Construction Manager Direction. Provide cleaning and protection upon completion of rooms or areas.
10. All costs for barricades, arrows, pedestrian protections, flag men, etc. will be part of this Contract. It shall be assumed there is at least 1 marked flagger to escort trucks through the project site.

11. Provide daily fine cleanup of the work is the responsibility of each individual Contractor which includes broom cleaning of their debris as required. Daily Fine clean up, on a daily basis, shall be defined as those means/methods utilized to perform the daily cleaning tasks without producing dust, noise and stacking of stored materials. Furnish fine clean up on a daily basis. All debris must be removed from the work area at the end of each work day to the appropriate dumpster.
12. Provide at least a 48 hour notice prior to any delivery. All deliveries are to be between 7:00 AM and 3:30 PM.
13. This is not a secure site. All contractors are responsible for concealing, locking and/or removing any materials on a daily basis. ASD and EDiS will not be responsible for any lost tools, materials or equipment.
14. Provide a \$10,000 allowance, included in base bid, to be used at the discretion of the Construction Manager.

CONTRACT NO. A-16 – CERAMIC TILE

A. Work included in this contract consists of, but is not necessarily limited to, all labor, materials and equipment for:

- Technical Specification Sections:

Division 0	Bidding and Contract Requirements
Division 1	General Requirements
<del>Section 078413</del>	<del>Penetration Firestopping</del>
Section 079200	Joint Sealants
Section 093000	Tiling
<del>Section 097720</del>	<del>Fiberglass Reinforced Wall Panel</del> <b>(BP1 ADDENDUM NO. 2)</b>

This contract also includes, but is not necessarily limited to, all labor, materials and equipment for the following:

1. Provide ceramic tile, quarry tile, porcelain tile, glazed wall tile, stone thresholds and associated systems, membranes, setting materials, epoxy grouts (where indicated), sealers and strips. Resinous flooring will be by provided by the Resinous Flooring contractor.
2. Provide setting beds and thin set applications as directed.
3. ~~Provide vapor retarding where applicable. (BP1 ADDENDUM NO. 2)~~
4. ~~Provide waterproofing and anti fracture membrane at all tile locations as specified by the project documents. (BP1 ADDENDUM NO. 2)~~
5. Provide cutting and fitting around work installed by others.
6. Provide patching **and leveling of existing walls to receive ceramic tile. (BP1 ADDENDUM NO. 2)**
7. ~~Provide crack suppression membrane for this set tile installation. (BP1 ADDENDUM NO. 2)~~
8. ~~Provide cementitious backer units as part of the tile installation. (BP1 ADDENDUM NO. 2)~~
9. Provide metal trim pieces (Schluter strips, etc.) integral to the tile installations.
10. Provide metal strips installed as part of the tile installation.
11. Provide mock ups as specified.
12. Provide protection, maintenance and the removal of finished products once accepted by Construction Manager. Protection shall consist of Ram Board or equal flooring protection, secured and covering all areas of wood floor and Masonite over high traffic areas on top of the

flooring protection. (If recommended by tile manufacturer, provide coat of protective cleaner to all floors and walls. Do not remove until Construction Manager Direction. Upon notice from Construction Manager, remove protective cleaner from the tile surfaces for final inspection.

13. Provide attic stock.
14. Provide pricing for all alternates as described in Section 012300-Alternates.
15. This contractor must provide a silica exposure plan that meets or exceeds the new 2017 silica OSHA requirements before any work can commence. At a minimum, it must be implemented in to the company safety plan, include all monitoring, testing, limits exposure, provide respiratory plan and/or equipment modifications such as adding water to equipment during exposed work and keep records of exposure.
16. All costs for barricades, arrows, pedestrian protections, flag men, etc. will be part of this Contract. It shall be assumed there is at least 1 marked flagger to escort trucks through the project site.
17. Provide daily fine cleanup of the work is the responsibility of each individual Contractor which includes broom cleaning of their debris as required. Daily Fine clean up, on a daily basis, shall be defined as those means/methods utilized to perform the daily cleaning tasks without producing dust, noise and stacking of stored materials. Furnish fine clean up on a daily basis. All debris must be removed from the work area at the end of each work day to the appropriate dumpster.
18. Provide at least a 48 hour notice prior to any delivery. All deliveries are to be between 7:00 AM and 3:30 PM.
19. This is not a secure site. All contractors are responsible for concealing, locking and/or removing any materials on a daily basis. ASD and EDiS will not be responsible for any lost tools, materials or equipment.
20. Provide a \$5,000 allowance, included in base bid, to be used at the discretion of the Construction Manager.



CONTRACT NO. A-17 - KITCHEN EQUIPMENT

A. Work included in this contract consists of, but is not necessarily limited to, all labor, materials and equipment for:

- Technical Specification Sections:

Division 0	Bidding and Contract Requirements
Division 1	General Requirements
Section 078413	Penetration Firestopping
Section 079200	Joint Sealants
Section 083113	Access Doors and Frames
Section 114000	Food Service Equipment

This contract also includes, but is not necessarily limited to, all labor, materials and equipment for the following:

1. Provide all materials, services, equipment and appliances necessary to provide all foodservice equipment to its final installation location as specified.
2. All final connections shall be made by the Electrical and Mechanical Contractors. Provide coordination with Special Systems, Electrical and Mechanical contractor to prevent any additional cost to the Owner.
3. Any discrepancies between the Drawings, Specifications and site conditions or ambiguities in the documents shall immediately be reported to the Construction Manager in writing. Inconsistencies shall be corrected in writing or by reissuing the drawings. If the Contract Documents disagree with the quality or quantity of work required, the better quality or greater quantity shall be supplied unless otherwise instructed in writing by the Construction Manager. Any work performed by the Contractor at locations in question after his discovery of discrepancies, inconsistencies, ambiguities, or errors, without securing resolution, shall be at the Contractor’s risk.
4. This Contractor shall verify all measurements at the site and assume full responsibility for their correctness before proceeding with his work. No extra compensation will be allowed because of differences between site conditions and those indicated on the drawings.
5. Manufactured articles, materials, and equipment shall be applied, installed, connected, erected, used, cleaned and conditioned as directed by the manufacturer and shall be protected from damage until acceptance. Prefinished products which are damaged before or after installation shall be replaced with new and perfect materials. Materials finished after installation which are damaged shall be refinished or replaced as the Construction Manager may direct. No additional charge will be honored by the Construction Manager for repair or replacement of finished materials.
6. Should this Contractor feel that the Contract Documents call for work which he cannot

- guarantee, he shall so state, in writing, prior to bidding. Proceeding with any operation shall be construed as acceptance of all guarantee conditions.
7. Secure certificates of inspection and occupancy required by authorities having jurisdiction. Deliver copies of certificates to the Construction Manager prior to filing application for final payment.
  8. It is this Contractor's responsibility to make certain statutes, building codes, and regulations including those of the appropriate health agencies having jurisdiction over this type of facility are met.
  9. Provide access doors and frames for all access to Kitchen Equipment components or equipment that require routine or periodic maintenance.
  10. Any items furnished as part of this Scope of Work that require mechanical or electrical rough ins or services that are different from those shown on the Contract Drawings shall be so noted at the time of bid. Failure to do so shall make this Contractor liable for costs of any changes required by same.
  11. Provide all caulking and sealants for proper installation and in accordance with public health regulations.
  12. Start, test, demonstrate and training owner all equipment installed under this category of work prior to substantial completion. Provide O&M manuals and proposed schedule, including names and telephone numbers of attending representatives (3) three weeks in advance of demonstration.
  13. Obtain approvals and permits and coordinate inspections and testing with governing local and state agencies.
  14. Provide connections and services to building management & alarm systems not included in electrical scope, specifically relative to exhaust hoods, walk-in cooler/freezer, & kitchen equipment alarms, etc.
  15. All costs for barricades, arrows, pedestrian protections, flag men, etc. will be part of this Contract. It shall be assumed there is at least 1 marked flagger to escort trucks through the project site.
  16. Provide daily fine cleanup of the work is the responsibility of each individual Contractor which includes broom cleaning of their debris as required. Daily Fine clean up, on a daily basis, shall be defined as those means/methods utilized to perform the daily cleaning tasks without producing dust, noise and stacking of stored materials. Furnish fine clean up on a daily basis. All debris must be removed from the work area at the end of each work day to the appropriate dumpster.
  17. Provide at least a 48 hour notice prior to any delivery. All deliveries are to be between 7:00

AM and 3:30 PM.

18. This is not a secure site. All contractors are responsible for concealing, locking and/or removing any materials on a daily basis. ASD and EDiS will not be responsible for any lost tools, materials or equipment.

CONTRACT NO. A-18 - FIRE PROTECTION

A. Work included in this contract consists of, but is not necessarily limited to, all labor, materials and equipment for:

- Technical Specification Sections:

Division 0	Bidding and Contract Requirements
Division 1	General Requirements
Section 078413	Penetration Firestopping
Section 079200	Joint Sealants
Section 083113	Access Doors and Frames
Section 114000	Food Service Equipment
Section 210170	Fire Suppression Sprinkler and Standpipe Systems
Section 220000	General Provisions – Plumbing/Fire Protection
Section 220010	Basic Materials and Methods – Plumbing
<del>Section 260851</del>	<del>Heating Terminals</del>
Section 280721	Fire Alarm and Detection Systems
<b>Division 22</b>	<b>Plumbing (BP1 ADDENDUM NO. 2)</b>
Division <del>1523</del>	Mechanical ( <b>BP1 ADDENDUM NO. 2</b> )
Division <del>1626</del>	Electrical ( <b>BP1 ADDENDUM NO. 2</b> )

This contract also includes, but is not necessarily limited to, all labor, materials and equipment for the following:

1. Provide piping, fittings, couplings, valves and sprinkler heads.
2. Provide as-built drawings.
3. Provide testing and inspections.
4. Provide cutting and patching.
5. Provide firesafing.
6. Provide design.
7. Provide flow and tamper switches to be supplied by this Contractor and wired by the Special Systems Contractor. It is this Contractors responsibility to provide flow and tamper switches to meet applicable state and local codes.
8. This Contractor to coordinate the need for and compatibility of his system to the emergency generator, supplied by others.
9. Provide pipe identification.

10. Provide the necessary coordination with trade to avoid interferences with other work and make corrections at no extra charge.
11. Provide specified warranties.
12. Submissions will be reviewed once and any resubmittals will be reviewed once. Any other submittals will be billed to the contractor at the Engineers standard rates. Please thoroughly review all submissions prior to forwarding to avoid these costs.
13. Provide start up training and demonstration of new system.
14. Provide attic stock as specified.
15. All sprinkler heads to be located center of tile.
16. Provide access doors and frames panels for all access to Fire Protection components or equipment that require routine or periodic maintenance.
17. All costs for barricades, arrows, pedestrian protections, flag men, etc. will be part of this Contract. It shall be assumed there is at least 1 marked flagger to escort trucks through the project site.
18. Provide daily fine cleanup of the work is the responsibility of each individual Contractor which includes broom cleaning of their debris as required. Daily Fine clean up, on a daily basis, shall be defined as those means/methods utilized to perform the daily cleaning tasks without producing dust, noise and stacking of stored materials. Furnish fine clean up on a daily basis. All debris must be removed from the work area at the end of each work day to the appropriate dumpster.
19. Provide at least a 48 hour notice prior to any delivery. All deliveries are to be between 7:00 AM and 3:30 PM.
20. This is not a secure site. All contractors are responsible for concealing, locking and/or removing any materials on a daily basis. ASD and EDiS will not be responsible for any lost tools, materials or equipment.
21. Provide a \$5,000 allowance, included in base bid, to be used at the discretion of the Construction Manager.

CONTRACT NO. A-19 - MECHANICAL AND PLUMBING

A. Work included in this contract consists of, but is not necessarily limited to, all labor, materials and equipment for:

- Technical Specification Sections:

Division 0	Bidding and Contract Requirements
Division 1	General Requirements
Section 033000	Cast-In-Place Concrete
Section 078413	Penetration Firestopping
Section 079200	Joint Sealants
Section 083113	Access Doors and Frames
Section 114000	Food Service Equipment
Section 210170	Fire Suppression Sprinkler and Standpipe Systems
Section 220000	General Provisions – Plumbing/Fire Protection
Section 220010	Basic Materials and Methods – Plumbing
Section 220030	Insulation & Covering – Plumbing
Section 220110	Drainage Systems – Plumbing
Section 220120	Domestic Water Systems – Plumbing
Section 220130	Gas Piping Systems – Plumbing
Section 220140	Fixtures – Plumbing
Section 220150	Equipment – Plumbing
Section 220190	Testing – Plumbing
Section 220191	Balancing – Plumbing
Section 230200	General Provisions – HVAC
Section 230210	Basic Materials and Methods – HVAC
Section 230215	Valves
Section 230230	Insulation & Covering – HVAC
Section 230300	Vibration and Sound Isolation – HVAC
Section 230400	Heating Generation Equipment
Section 230410	Heating Generation Auxiliary Equipment
Section 230450	Refrigeration Equipment – HVAC
Section 230500	Piping Systems & Accessories – HVAC
Section 230510	Water Treatment (HVAC)
Section 230600	Air Distribution & Accessories – HVAC
Section 230605	Fans
Section 230725	Terminal Heating Units
Section 230760	Air Handling Equipment
Section 230861	Air Purification System
Section 230900	Automatic Temperature Control
Section 230950	Testing & Balancing of Mechanical Systems
Section 260155	Motor Starters
Section 260851	Heating Terminals
Section 280721	Fire Alarm and Detection Systems
<del>Division 15</del>	<del>Mechanical</del>

Division ~~1626~~ Electrical

This contract also includes, but is not necessarily limited to, all labor, materials and equipment for the following:

1. Provide a complete mechanical, plumbing and piping system as indicated on the Drawings and in the Specifications.
2. The Demolition Contractor shall provide all concrete slab on grade demolition inside of building, as indicated in the construction documents. This contractor is responsible for coordination with Demolition contractor relative to concrete slabs that are to be removed for removal/installation of mechanical or plumbing systems. Layout of slab demolition related to mechanical or plumbing systems shall be provided by the Mechanical & Plumbing Contractor.
3. Prior to demolition, mechanical and plumbing systems scheduled for demolition will be safed-off, disconnected and capped or plugged by the Mechanical & Plumbing Contractor. **Refrigerant evacuation and disposal shall be the responsibility of this Contractor.** This Contractor shall be responsible for coordination with the Demolition Contractor prior to and during demolition activity. **(BPA ADDENDUM NO. 2)**
4. Division ~~16~~ **26** of the specifications should be reviewed as it relates to the power wiring and other requirements for HVAC equipment including the coordination of furnishing and installing motor starters as provided in the specifications. **(BP1 ADDENDUM NO. 2)**
5. This Contractor shall be responsible to designate an individual within his organization, intimately familiar with this project and assigned on site, to act as the System Start-up Coordinator. This individual must be pre-approved by the Construction Manager. This individual's responsibilities shall include, but not be limited to, coordinating the start-up of all mechanical equipment, including the coordination between the Electrical Contractor, the Building Management System Contractor, and all testing, adjusting and balancing work. This individual shall report on a weekly basis, in written form, to the Construction Manager. These reports shall include a summary of current conditions including manufacturers' start-ups, systems' deficiencies noted to date and the remediation of same, coordination issues between trades, system interfacing and forecasting, as necessary to project the completion of each individual system within the building.
6. Provide excavation and backfill for underground mechanical/plumbing work as detailed below is the responsibility of this Contractor. Soil types shall be in accordance with project documents.
7. Provide all Equipment bases and housekeeping pads related to plumbing and HVAC equipment.
8. ~~Provide permits/meters.~~ **(BP1 ADDENDUM NO. 2)**

9. Provide pipe and duct systems insulation.
10. Coordinate and provide penetrations through wall, floors, etc. including cutting, patching and fire safing. The contractor requiring wall sleeves in concrete & masonry walls must supply and locate these to the concrete and masonry contractors for them to install.
11. Coordinate with the Testing and Balancing Contractor.
12. All guarantees and warranties to begin at the substantial completion of the entire project. Maintain equipment prior to substantial completion.
13. Provide all cranes, scaffolding and lifts for this work including any rigging.
14. Provide coordination with Building Management Systems Contractor.
15. Provide ductwork, flex duct, grilles and diffusers.
16. Provide roof drains.
17. Provide louvers and vents related to HVAC operations.
18. Coordinate damper size, location and type of damper with architectural drawings.
19. Provide piping work associated with the emergency generator (including fuel piping and exhaust piping). Include initial fill up of fuel tanks.
20. Provide temporary heat and ventilation installation, maintenance and removal. Refer to Division 1, Specification Section 015123 - TEMPORARY HEATING, COOLING, & VENTILATION, for specific scope. The new equipment WILL NOT be used for temporary heating; **however the equipment will be started and put into service as needed to connect and integrate with Building Management System and to conduct testing, adjusting, and balancing (TAB)**. This Subcontractor will furnish, install, and maintain the temporary heating equipment. Temporary heating fuel consumption associated with the temporary heating will be applied to the contract Allowance. **(BP1 ADDENDUM NO. 2)**
21. Provide gas piping, meter, regulators and pressure regulator valve.
22. Provide electric baseboard heat.
23. Provide duct testing to be verified by the TAB Contractor.
24. Provide precast mop receptors
25. Provide grease/trap interceptor system and vault. Include excavation & backfill and any stone, tie-downs or foundation requirements. **Provide all piping outside of the building upstream and downstream of the interceptor to provide a complete system as shown on**



**Drawing P30.2. (BP1 ADDENDUM NO. 2)**

26. Provide trap ~~priming system~~ **seal protection system. (BP1 ADDENDUM NO. 2)**
27. Provide fuel detection/monitoring system in accordance with local codes.
26. Roof curbs, pipe, hoods and vent equipment & supports are to be supplied by contractor in which the units, piping, etc. are being supplied. The openings for the curbs in the roofing materials shall be cut by the Roofing Contractor. Openings in the metal deck shall be cut by the contractor in which the units are being provided. The roofing contractor shall provide all flashing and sealing of the curbs. Any wood blocking required will be provided by Carpentry & General Works Contractor. **This Contractor shall provide delegated design of roof curbs and roof mounted equipment supports, refer to specification Section 077200 – Roofing Accessories. (BP1 ADDENDUM NO. 2)**
28. All utilities will be brought to within +/- 5 feet of the building line by others. The Mechanical Contractor is responsible for connecting the utilities from +/- 5 feet outside the building line and completing the system within the building.
29. Install Owner prepurchased equipment, if applicable.
30. Furnish access doors and frames for all access to Mechanical or Plumbing components or equipment that require routine or periodic maintenance. Installation of access doors and frames provided by the Metal Stud & Drywall Contractor.
31. Provide final connection of kitchen equipment and appliances.
32. Provide as-built drawings.
33. Provide pricing for all alternates as described in Section 012300-Alternates.
34. Provide rough-in and final connection of kitchen equipment and appliances. Refer to Specification Section 11400 Food Service Equipment for specifics. Coordinate water and sanitary drainage requirements with rough in for equipment with the Kitchen Equipment Contractor.
35. ~~Coordinate with Sitework Contractor, who will provide all tie ins to the downstream side of grease trap and Electrical Contractor. This contractor, shall provide all excavation, backfill and piping from building to grease trap. It is the intent that no additional costs will be provided for lack of coordination that requires relocation of newly installed site utilities for the installation of the grease trap. (BP1 ADDENDUM NO. 2)~~
36. Provide floor drains/trenches in kitchen, ~~showers~~, as detailed in the Construction Documents. The Concrete Contractor and this Contractor are to coordinate drain rim elevation to achieve positive drainage and ensure that there are no additional costs to the Owner for field adjustments. **(BP1 ADDENDUM NO. 2)**

37. Provide data and submittal information related to the Scope of this Contract signed and sealed by a Professional Engineer as required by the Contract Documents, including but not limited to delegated design requirements in specifications.
38. All costs for barricades, arrows, pedestrian protections, flag men, etc. will be part of this Contract. It shall be assumed there is at least 1 marked flagger to escort trucks through the project site.
39. Provide daily fine cleanup of the work is the responsibility of each individual Contractor which includes broom cleaning of their debris as required. Daily Fine clean up, on a daily basis, shall be defined as those means/methods utilized to perform the daily cleaning tasks without producing dust, noise and stacking of stored materials. Furnish fine clean up on a daily basis. All debris must be removed from the work area at the end of each work day to the appropriate dumpster.
40. Provide at least a 48 hour notice prior to any delivery. All deliveries are to be between 7:00 AM and 3:30 PM.
41. This is not a secure site. All contractors are responsible for concealing, locking and/or removing any materials on a daily basis. ASD and EDiS will not be responsible for any lost tools, materials or equipment.
42. Provide a \$50,000 allowance, included in base bid, to be used at the discretion of the Construction Manager.
43. **Before ANY excavation work is to commence, the Contractor/Excavator shall contact the utility companies or utility owners and advise them of the proposed work and ask them to mark the location of the underground utility installations. This notification shall be done within established or customary local response times. If the work is on private property and the utility company will not mark out the utilities, the Contractor/Excavator will hire a private locating service to mark the utilities. Once the utilities are located and marked, the Contractor/Excavator will excavate by hand or use a vacuum truck to expose the utilities and record the exact location and elevation of the utilities. The Contractor/Excavator must submit the Excavation Permit to EDiS Company verifying their assurance of communication with the utility companies or utility owners. The Contractor/Excavator must follow State, Local, and Federal Guidelines prior to proceeding with excavations. The Contractor/Excavator will have these marks restored as long as there is work to perform. Once the Contractor has installed new utilities, they will provide to EDiS Company an as-built drawing, within 7 days, showing the exact location and elevation of the utilities. The installing Contractor will be responsible for locating and marking these utilities for other contractors that may have work in the same area. (BP1 ADDENDUM NO. 2)**
- 44.



CONTRACT NO. A-20 – BUILDING MANAGEMENT SYSTEMS

A. Work included in this contract consists of, but is not necessarily limited to, all labor, materials and equipment for:

- Technical Specification Sections:

Division 0	Bidding and Contract Requirements
Division 1	General Requirements
Section 078413	Penetration Firestopping
Section 079200	Joint Sealants
Section 083113	Access Doors and Frames
Section 230900	Automatic Temperature Control
Section 230950	Testing & Balancing of Mechanical Systems
<b>Division 23</b>	<b>Mechanical (BP1 ADDENDUM NO. 2)</b>
Division 26	Electrical

This contract also includes, but is not necessarily limited to, all labor, materials and equipment for the following:

1. Provide automatic temperature controls for equipment whose main purpose include all items in the automatic temperature control scope. Provided, however, that the controls do not directly switch the power lines to the equipment; the wiring of such controls to remain the responsibility under Contract Scope 16000.
2. Provide environmental controls.
3. Provide ventilation controls.
4. Provide cooling controls.
5. Provide humidification controls.
6. Provide HVAC refrigeration controls.
7. Provide BMS interface for all kitchen equipment as indicated in the construction documents. Kitchen Equipment Contractor shall provide connections and services to building management, specifically relative to exhaust hoods, walk-in cooler/freezer, & kitchen equipment alarms, etc.
8. Motorized dampers when not specified as part of the factory packaged equipment supplied to job site for distribution and installation by others.
9. Provide both reading and remote gauges, transmitters and recorders for automatic temperature controls.

10. Provide building centralization controls including but not limited to centralized temperature, humidity, pressure and flow indication and recorders, centralization of air conditioning, heating, ventilation, humidification and refrigeration equipment operation. Provide integration of all equipment as required by the Construction Documents.
11. Provide building life safety control and equipment safety control including: fire alarm, fan shut downs, operators and controls for motorized smoke dampers, operators and controls for motorized fire dampers, firestats, freeze protection thermostats, shut down safety devices forming part of automatic temperature control.
- ~~12. Provide permits as required for work under this contract scope. (BP1 ADDENDUM NO. 2)~~
13. Provide inspections as required under this contract scope.
14. Provide electrical thermostats intended for automatic temperature controls complete with subbases or adapter plates to mount on standard electrical box.
15. Provide access doors and frames for all access to Building Management System components or equipment that require routine or periodic maintenance. Installation of access doors and frames provided by the Metal Stud & Drywall Contractor.
16. Provide control wiring ~~and/or air piping~~ required for all automatic temperature controls supplied under this contract scope. **(BP1 ADDENDUM NO. 2)**
17. Provide wiring for remote thermostats and remote prewired auxiliary control panels for packaged equipment.
18. Provide boiler feed water control wiring.
19. Provide magnetic starter coil and relay coils intended for automatic temperature controls, including interlocking between starters and/or relays when controlled automatically.
20. Exclude direct reading temperature and pressure gauges connected directly to non-potable water systems.
21. Exclude motorized dampers when specified as integral part of packaged equipment.
22. Exclude automatic temperature controls when specified as integral part of packaged equipment.
- ~~23. Exclude flow measuring and control devices. (BP1 ADDENDUM NO. 2)~~
24. Exclude direct reading temperature and pressure gauges connected directly to refrigeration systems.

25. Exclude filter gauges directly connected to duct systems.
26. Provide electrical wiring for thermostats and controls which directly switch the power line to the equipment (directly shall mean not through magnetic coil) is by Division ~~16000~~ **26 - Electrical. (BP1 ADDENDUM NO. 2)**
27. Power wiring are to be provided by the Electrical Contractor.
28. Control power supply outlets are to be provided by the Electrical Contractor.
29. Exclude fire alarm, fan shut-down, relays and wiring Section ~~16720~~ **28 07 21.**
30. Provide pricing for all alternates as described in Section 012300-Alternates.
31. Provide transmitters for ATC.
32. Start, test and demonstrate all equipment installed under this category of work. Provide proposed schedule, including names and telephone numbers of attending representatives at least (3) three weeks in advance of demonstration.
33. Submissions will be reviewed once and any resubmittals will be reviewed once. Any other submittals will be billed to the contractor at the Engineers standard rates. Please thoroughly review all submissions prior to forwarding to avoid these costs.
34. All costs for barricades, arrows, pedestrian protections, flag men, etc. will be part of this Contract. It shall be assumed there is at least 1 marked flagger to escort trucks through the project site.
35. Provide daily fine cleanup of the work is the responsibility of each individual Contractor which includes broom cleaning of their debris as required. Daily Fine clean up, on a daily basis, shall be defined as those means/methods utilized to perform the daily cleaning tasks without producing dust, noise and stacking of stored materials. Furnish fine clean up on a daily basis. All debris must be removed from the work area at the end of each work day to the appropriate dumpster.
36. Provide at least a 48 hour notice prior to any delivery. All deliveries are to be between 7:00 AM and 3:30 PM.
37. This is not a secure site. All contractors are responsible for concealing, locking and/or removing any materials on a daily basis. ASD and EDiS will not be responsible for any lost tools, materials or equipment.

CONTRACT NO. A-21 - ELECTRICAL

A. Work included in this contract consists of, but is not necessarily limited to, all labor, materials and equipment for:

- Technical Specification Sections:

Division 0	Bidding and Contract Requirements
Division 1	General Requirements
Section 033000	Cast-In-Place Concrete
Section 078413	Penetration Firestopping
Section 079200	Joint Sealants
Section 087100	Door Hardware
Section 102239	Folding Panel Partitions
Section 114000	Food Service Equipment
Section 115213	Projection Screens
Section 116623	Gymnasium Equipment
Section 210170	Fire Suppression Sprinkler and Standpipe Systems
Section 260000	General Provisions – Electrical
Section 260055	Electrical Identification
Section 260110	Raceways
Section 260120	Wires & Cables
<del>Section 260130</del>	<del>Manholes</del> <b>(BP1 ADDENDUM NO. 2)</b>
Section 260135	Electrical Boxes & Fittings
Section 260140	Wiring Devices
Section 260155	Motor Starters
Section 260160	Panelboards
Section 260165	Switchboards
Section 260170	Motor and Circuit Disconnects
Section 260180	Overcurrent Protective Devices
Section 260190	Supporting Devices
Section 260195	Power System Studies
Section 260452	Grounding
Section 260460	Transformers
Section 260470	Distribution Circuits
Section 260471	Feeder Circuits
Section 260472	Branch Circuits
Section 260510	Building Lighting
Section 260520	Roadway & Parking Area Lighting
Section 260601	Lightning Protection Systems - <b>Alternate #12) (BP1 ADDENDUM NO. 2)</b>
Section 260851	Heating Terminals
Section 260930	Dimming Controls
<b>Division 23</b>	<b>Mechanical/HVAC (BP1 ADDENDUM NO. 2)</b>
<b>Division 28</b>	<b>Electrical Safety and Security (BP1 ADDENDUM NO. 2)</b>

This contract also includes, but is not necessarily limited to, all labor, materials and equipment for the following:

1. Provide a complete electrical system as indicated on the drawings, schedules and in the specifications.
2. Divisions 22 and 23 of the specifications should be reviewed as it relates to the power wiring and other requirements for Plumbing and HVAC equipment including the coordination of furnishing and installing motor starters and controllers as detailed in the Specifications and on the Drawings.
3. Provide and coordinate permits, testing, and inspections.
4. Provide temporary electric installation, maintenance and removal. Refer to Division 1, Specification Section 015113 - TEMPORARY ELECTRIC, for specific scope.
5. Prior to demolition, electrical circuits to equipment to be demolished will be safed-off and disconnected by the Electrical Contractor. This Contractor shall be responsible for coordination with the Demolition Contractor prior to and during demolition activity.
6. The Demolition Contractor shall provide all concrete slab on grade demolition inside of building, as indicated in the construction documents. This contractor is responsible for coordination with Demolition contractor relative to concrete slabs that are to be removed for removal/installation of electrical systems. Layout of slab demolition related to electrical systems shall be provided by the Electrical Contractor.
7. Excavation and backfill for underground electrical work as required below is the responsibility of this Contractor. Soil types shall be in accordance with project documents.
8. Provide concrete for duct banks, light standards, above ground conduit encasement, equipment bases and any other concrete work specifically related to the electrical work. Include requirements of ~~New Castle County~~ **the Town of Middletown**, State and local codes for concrete encasement. **(BP1 ADDENDUM NO. 2)**
9. Provide rough in and final connection and related work for equipment provided under other contracts (i.e. kitchen, HVAC, sprinkler, motorized doors, special systems, etc.)
10. The Concrete Contractor shall furnish, install and maintain stone fill under slab. The Sitework Contractor shall leave the building pad site at subgrade to within +/- 1/4" in preparation to receive stone fill. The Mechanical and Electrical Contractors shall complete their work under the slab on grade and shall be responsible to return the pad to the subgrade elevation left by the Sitework Contractor. The Concrete Contractor shall then adjust the select material to final subgrade, fine grade the slab and place the vapor barrier and stone fill.



11. All guarantees and warranties to begin at the substantial completion of the entire project. Maintain equipment prior to substantial completion.
12. Provide penetrations through walls, floors, etc. including cutting, patching and fire safing.
13. Provide hoisting, rigging and scaffolding.
14. Provide all primary service work, including all utility company related costs/fees for this work.
15. Provide all heat tracing.
16. ~~Provide lightning protection system with master UL certification. (BP1 ADDENDUM NO. 2)~~
17. Provide grounding of building columns and interior spaces as required.
18. Provide boxes, pathways, and pull strings for low voltage cables provided by the Special Services and Structure Cable Contractors.
19. Provide as-built drawings.
20. Provide rough-in and final connection and related work for equipment provided under other contracts (i.e. kitchen, elevators, HVAC, sprinkler, motorized doors, etc.). **(BP1 ADDENDUM NO. 2)**
21. Provide rough-in and final connection of kitchen equipment and appliances. Refer to Specification Section 11400 Food Service Equipment for specifics. Coordinate power/plug requirements with rough in for equipment with the Kitchen Equipment Contractor. Electrical Contractor is responsible for all items within the Kitchen Equipment Plans and Specifications that are indicated as "by electrical contractor".
22. Provide stage lighting systems including fixtures, controls, wiring, light grids, supports and attachments.
23. Provide pricing for all alternates as described in Section 012300-Alternates.
24. Submissions will be reviewed once and any resubmittals will be reviewed once. Any other submittals will be billed to the contractor at the Engineers standard rates. Please thoroughly review all submissions prior to forwarding to avoid these costs.
25. Provide power to hand dryers. The hand dryers will be supplied and installed by Carpentry & General Works Contractor.
26. Projectors and mounts for the cafetorium sound reinforcement audio/visual system provided by the owner and installed by the this Contractor.

27. The contractor responsible for supplying the doors, frames, and hardware shall provide all wiring and accessories from the power supply **(or junction box)** to the door hardware. The contractor responsible for installation of doors and hardware shall provide terminations from door hardware to door whip, from door whip to power transfer, and from frame whip to power transfer. Frame whip shall be secured and protected by the door, frame, and hardware contractor(s) for the direct access of the Special Systems Contractor. Termination of the frame whip to the power supply **(or junction box)** shall be provided by the Special Systems Contractor. Power supply shall be furnished by the door, frame, and hardware contractor(s) and installed by the Special Systems Contractor. The Special Systems Contractor shall provide low-voltage wire from the card reader to the access controller, from the status switch (door contact) to the access controller, from access controller to the power supply **(or junction box)**, and from power supply **(or junction box)** to power supply **(or junction box)** as necessary. The Electrical Contractor is responsible for providing 120v circuits to all power supplies and/or transformers as indicated in the documents. The Electrical Contractor shall provide conduits, device boxes, raceways, and pull strings for low-voltage wiring at doors receiving electronic, security, or access control hardware. Electrical contractor shall provide a junction box above each door scheduled to receive a card reader and a pathway & pull string. A mock-up shall be field installed and coordinated by all related Contractors for review prior to commencing work. **(BP1 ADDENDUM NO. 2)**
28. Provide power circuits to all systems installed by the Special Systems Contractor including, but not necessarily limited to the following: Wireless Clock System, Intercom/Public Address System, Fire Alarm System, Cafetorium Sound Reinforcement System, Access Control System, CCTV System.
29. Provide power circuits for electrified hold open hardware. Hold open hardware provided by Carpentry and General Work Contractor. Fire alarm wiring, terminations, and programming by Special Systems Contractor. Special Systems Contractor shall provide low-voltage power to door hold open hardware.
30. Provide site lighting **systems** and all reinforced lighting bases and associated conduit. **(BP1 ADDENDUM NO. 2)**
31. Provide proper coordination with Painting Contractor to ensure that exposed boxes, raceways, and conduit ~~is~~ **are** painted ~~at the~~ simultaneous to adjacent construction. Any costs that arise from out of sequence painting of exposed boxes, raceways, and conduits will be the responsibility of this Contractor. **(BP1 ADDENDUM NO. 2)**
32. All costs for barricades, arrows, pedestrian protections, flag men, etc. will be part of this Contract. It shall be assumed there is at least 1 marked flagger to escort trucks through the project site.
33. Provide daily fine cleanup of the work is the responsibility of each individual Contractor which includes broom cleaning of their debris as required. Daily Fine clean up, on a daily

basis, shall be defined as those means/methods utilized to perform the daily cleaning tasks without producing dust, noise and stacking of stored materials. Furnish fine clean up on a daily basis. All debris must be removed from the work area at the end of each work day to the appropriate dumpster.

34. Provide at least a 48 hour notice prior to any delivery. All deliveries are to be between 7:00 AM and 3:30 PM.
35. This is not a secure site. All contractors are responsible for concealing, locking and/or removing any materials on a daily basis. ASD and EDiS will not be responsible for any lost tools, materials or equipment.
36. Provide a \$40,000 allowance, included in base bid, to be used at the discretion of the Construction Manager.
37. **Before ANY excavation work is to commence, the Contractor/Excavator shall contact the utility companies or utility owners and advise them of the proposed work and ask them to mark the location of the underground utility installations. This notification shall be done within established or customary local response times. If the work is on private property and the utility company will not mark out the utilities, the Contractor/Excavator will hire a private locating service to mark the utilities. Once the utilities are located and marked, the Contractor/Excavator will excavate by hand or use a vacuum truck to expose the utilities and record the exact location and elevation of the utilities. The Contractor/Excavator must submit the Excavation Permit to EDiS Company verifying their assurance of communication with the utility companies or utility owners. The Contractor/Excavator must follow State, Local, and Federal Guidelines prior to proceeding with excavations. The Contractor/Excavator will have these marks restored as long as there is work to perform. Once the Contractor has installed new utilities, they will provide to EDiS Company an as-built drawing, within 7 days, showing the exact location and elevation of the utilities. The installing Contractor will be responsible for locating and marking these utilities for other contractors that may have work in the same area. (BP1 ADDENDUM NO. 2)**

CONTRACT NO. A-22 – SPECIAL SYSTEMS

A. Work included in this contract consists of, but is not necessarily limited to, all labor, materials and equipment for:

- Technical Specification Sections:

Division 0	Bidding and Contract Requirements
Division 1	General Requirements
Section 078413	Penetration Firestopping
Section 079200	Joint Sealants
Section 083113	Access Doors and Frames
Section 087100	Door Hardware
Section 114000	Food Service Equipment
Section 210170	Fire Suppression Sprinkler and Standpipe Systems
Section 260731	Wireless Clock System
Section 260740	Network Cabling Systems
Section 260771	Intercom/Telecommunication and Clock System
Section 260772	Cafetorium Sound Reinforcement System
Section 280721	Fire Alarm and Detection Systems
Section 280725	Intrusion System
Section 280727	Integrated Access Control & Security Management System
Section 280728	CCTV – Network Digital Video Management System

This contract also includes, but is not necessarily limited to, all labor, materials and equipment for the following:

1. Provide wireless clock system including all equipment, cable, and accessories.
2. Telephone and voicemail system including telephone handsets and patch cables from device to jack will be provided by owner.
3. Provide intercom/public address system. Structured Cable Contractor will provide all network cabling including wiring, devices, and terminations at the source (MDF/IDF patch panel) and at the communication port (jack).
4. Provide complete cafetorium sound reinforcement audio/visual system. Projectors and mounts provided by the owner and installed by the Electrical Contractor.
5. Provide complete fire alarm system is to be provided by this contractor including all equipment, cable, and accessories. Water flow devices are supplied and installed by the Fire Protection Contractor and wired by this Contractor. Include tie-in to fire sprinkler flow and tamper switch. Fire alarm wiring, terminations, and programming of electrified hold open hardware by Special Systems Contractor. Low voltage power to electrified hold open hardware by Special Systems Contractor. Hold open hardware provided by Carpentry and General Work Contractor.

6. Provide complete intrusion system.
7. Provide access control and security management system. **This Contractor to expand the existing district wide card access system to cover this entire building as indicated.** Provide coordination with door and frame installation for a complete system. The contractor responsible for supplying the doors, frames, and hardware shall provide all wiring and accessories from the power supply (**or junction box**) to the door hardware. The contractor responsible for installation of doors and hardware shall provide terminations from door hardware to door whip, from door whip to power transfer, and from frame whip to power transfer. Frame whip shall be secured and protected by the door, frame, and hardware contractor(s) for the direct access of the Special Systems Contractor. Termination of the frame whip to the power supply (**or junction box**) shall be provided by the Special Systems Contractor. Power supply shall be furnished by the door, frame, and hardware contractor(s) and installed by the Special Systems Contractor. The Special Systems Contractor shall provide low-voltage wire from the card reader to the access controller, from the status switch (door contact) to the access controller, from access controller to the power supply (**or junction box**), and from power supply (**or junction box**) to power supply (**or junction box**) as necessary. The Electrical Contractor is responsible for providing 120v circuits to all power supplies and/or transformers as indicated in the documents. The Electrical Contractor shall provide conduits, device boxes, raceways, and pull strings for low-voltage wiring at doors receiving electronic, security, or access control hardware. Electrical contractor shall provide a junction box above each door scheduled to receive a card reader and a pathway & pull string. A mock-up shall be field installed and coordinated by all related Contractors for review prior to commencing work. **(BP1 ADDENDUM NO. 2)**
8. Provide a complete CCTV - Network Digital Video Management System. Owner shall provide server.
9. Provide all patch cords from communication port (jack) to each device included in this Contractor's scope. Patch cords at source (MDF/IDF) from patch panel to network switch provided by owner.
10. Provide coordination of the work of this contract with the Electrical and Structured Cable Contractor, including final equipment locations. This contractor must coordinate with Electrical Contractor as indicated on the drawings and as specified. The Electrical Contractor shall provide all device boxes, conduit and pull strings to circuits for special systems as indicated and also to provide 120 Volt circuits for all Special Systems. This Contractor will be responsible for providing **independent support systems**, as indicated in the specifications, for all cable and wiring installed by this Contractor in locations where pathways and raceways are not required by the documents.
11. Smart TVs/displays and mounting brackets will be supplied by Owner and mounted by the Carpentry & General Works Contractor. The Carpentry and General Works Contractor will coordinate blocking with mounting hardware and install all necessary clips and blocking to the wall for hanging. Audio/visual interface and/or controls by Special Systems Contractor.
12. Hardware for permanent exterior gates will be provided by the Sitework Contractor and

- installed by Carpentry & General Works Contractor. Access control hardware/software and fire alarm integrations of gate hardware, including terminations, cabling, etc. will be provided by the Special Systems Contractor. The Electrical Contractors shall provide all pathways & electrical requirements to support installation.
13. Provide access doors and frames for all access to Special Systems components or equipment that require routine or periodic maintenance. Installation of access doors and frames provided by the Metal Stud & Drywall Contractor.
  14. Provide penetrations through walls, floors, etc., including cutting, patching and fire safing.
  15. Provide all design and coordination necessary to provide complete systems.
  16. Provide and coordinate for inspections and testing.
  - ~~17. Provide permits for work of this contract. (BP1 ADDENDUM NO. 2)~~
  18. Provide fire resistive sealants for the work of this contract.
  19. Provide pricing for all alternates as described in Section 012300-Alternates.
  20. Submissions will be reviewed once and any resubmittals will be reviewed once. Any other submittals will be billed to the contractor at the Engineers standard rates. Please thoroughly review all submissions prior to forwarding to avoid these costs.
  21. All costs for barricades, arrows, pedestrian protections, flag men, etc. will be part of this Contract. It shall be assumed there is at least 1 marked flagger to escort trucks through the project site.
  22. Provide daily fine cleanup of the work is the responsibility of each individual Contractor which includes broom cleaning of their debris as required. Daily Fine clean up, on a daily basis, shall be defined as those means/methods utilized to perform the daily cleaning tasks without producing dust, noise and stacking of stored materials. Furnish fine clean up on a daily basis. All debris must be removed from the work area at the end of each work day to the appropriate dumpster.
  23. Provide at least a 48 hour notice prior to any delivery. All deliveries are to be between 7:00 AM and 3:30 PM.
  24. This is not a secure site. All contractors are responsible for concealing, locking and/or removing any materials on a daily basis. ASD and EDiS will not be responsible for any lost tools, materials or equipment.
  - 25. Provide video documentation of training on systems. (BP1 ADDENDUM NO. 2)**

CONTRACT NO. A-23 – STRUCTURED CABLE

A. Work included in this contract consists of, but is not necessarily limited to, all labor, materials and equipment for:

- Technical Specification Sections:

Division 0	Bidding and Contract Requirements
Division 1	General Requirements
Section 078413	Penetration Firestopping
Section 079200	Joint Sealants
Section 083113	Access Doors and Frames
Section 087100	Door Hardware
Section 114000	Food Service Equipment
Section 210170	Fire Suppression Sprinkler and Standpipe Systems
Section 260740	Network Cabling Systems
Section 260771	Intercom/Telecommunication and Clock System
Section 260772	Cafetorium Sound Reinforcement System
Section 280727	Integrated Access Control & Security Management System
Section 280728	CCTV – Network Digital Video Management System

This contract also includes, but is not necessarily limited to, all labor, materials and equipment for the following:

1. Provide all network cabling including wiring, devices, and terminations to communication devices identified in plans and referenced on “Communications Outlet Configuration” chart on Drawing ~~E301~~ **E30.1**. Two (2) terminations should be provided (1) at the source (MDF/IDF patch panel) and (1) at the communication port (jack) in all instances. **(BP1 ADDENDUM NO. 2)**
  
2. Provide all network cabling including wiring, devices, and terminations for devices provided by the Special Systems Contractor, specifically to devices identified in plans and referenced on “Communications Outlet Configuration” chart on Drawing ~~E301~~ **E30.1**. Two (2) terminations should be provided (1) at the source (MDF/IDF patch panel) and (1) at the communication port (jack) in all instances. Structured Cable Contractor will provide cable installation for the following Special Systems Contractor installed systems: **(BP1 ADDENDUM NO. 2)**
  - a. Telephone system and voicemail system.
  - b. Cafetorium sound reinforcement system.
  - c. CCTV - Network Digital Video Management System.
  
3. The Structured Cable Contractor will provide ONLY network interface (data drops) installation for the following Special Systems Contractor installed systems:
  - a. Wireless clock system
  - b. Fire alarm system
  - c. Intercom/public address system

- d. Intrusion system
  - e. Access Control
4. ~~Provide data drops to all systems installed by the Special Systems Contractor including, but not necessarily limited to the following: Wireless Clock System, Intercom/Public Address System, Fire Alarm System, Cafetorium Sound Reinforcement System, Access Control System, CCTV System. This Contractor shall provide terminations at the source (MDF/IDF patch panel) and at the communication port (jack). (BP1 ADDENDUM NO. 2)~~
  5. Structured Cable Contractor will install communication wiring from the (3) access control panels to the source (MDF/IDF patch panel) including terminations on both ends. Location of access control panels to be coordinated with the documents, the Special Systems Contractor and the Construction Manager prior to installation.
  6. Structured Cable Contractor will install communication wiring from the intrusion control headend to the source (MDF/IDF patch panel) including terminations on both ends. This communication wiring shall include (1) dedicated POTS line from the MDF room to the intrusion control dialer. Location of intrusion control headend to be coordinated with the documents, the Special Systems Contractor and the Construction Manager prior to installation.
  7. Structured Cable Contractor will install communication wiring from the Fire Alarm Control Panel (FACP) to the source (MDF/IDF patch panel) including terminations on both ends. This communication wiring shall include (2) dedicated POTS line from the MDF room to the FACP dialer(s). Location of FACP to be coordinated with the documents, the Special Systems Contractor and the Construction Manager prior to installation.
  8. Structured Cable Contractor will install communication wiring from the intercom/public address amplifiers to the source (MDF/IDF patch panel) including terminations on both ends. Location of amplifiers to be coordinated with the documents, the Special Systems Contractor and the Construction Manager prior to installation. **Contractor should assume (3) amplifiers, one located in each MDF/IDF. (BP1 ADDENDUM NO. 2)**
  9. Structured Cable Contractor will install communication wiring from the **Building Management System BAS** headend to the source (MDF/IDF patch panel). Location of **Building Management System BAS** headend to be coordinated with the documents, the Mechanical Contractor, and the Construction Manager prior to installation. **(BP1 ADDENDUM NO. 2)**
  10. Structured Cable Contractor will install all network cable **within the kitchen and kitchen hood** identified on the Kitchen Equipment Drawings **K-104, K-501, K-502, K-503, K-504**. Final location of network drops to be coordinated with the documents, the Kitchen Equipment Contractor, and the Construction Manager prior to installation. **(BP1 ADDENDUM NO. 2)**
  11. Structured Cable Contractor will install communication wiring from the food management systems to the POS devices, menu display boards, and temperature monitoring systems, including terminations on both ends. Final location of the food management systems to be coordinated with the documents and the Construction Manager prior to installation.
  12. Provide **installation for** all wireless access points furnished by owner. Patch cords from



device to communication port (jack) provided by this Contractor.

13. Provide coordination of the work of this contract with the Electrical and Special Systems Contractor, including final equipment locations. This contractor must coordinate with Electrical Contractor as indicated on the drawings and as specified. The Electrical Contractor shall provide all device boxes, conduit and pull strings to circuits for special systems as indicated. This Contractor will be responsible for providing **independent support systems**, as indicated in the specifications, for all cable and wiring installed by this Contractor in locations where pathways and raceways are not required by the documents. **This Contractor shall provide all additional boxes and conduits where required to make a complete system. (BP1 ADDENDUM NO. 2)**
14. Perform certification testing of all cables and provide full close-out documentation.
15. Provide access doors and frames for all access to Structured Cable components or equipment that require routine or periodic maintenance. Installation of access doors and frames provided by the Metal Stud & Drywall Contractor.
16. All costs for barricades, arrows, pedestrian protections, flag men, etc. will be part of this Contract. It shall be assumed there is at least 1 marked flagger to escort trucks through the project site.
17. Provide daily fine cleanup of the work is the responsibility of each individual Contractor which includes broom cleaning of their debris as required. Daily Fine clean up, on a daily basis, shall be defined as those means/methods utilized to perform the daily cleaning tasks without producing dust, noise and stacking of stored materials. Furnish fine clean up on a daily basis. All debris must be removed from the work area at the end of each work day to the appropriate dumpster.
18. Provide at least a 48 hour notice prior to any delivery. All deliveries are to be between 7:00 AM and 3:30 PM.
19. This is not a secure site. All contractors are responsible for concealing, locking and/or removing any materials on a daily basis. ASD and EDiS will not be responsible for any lost tools, materials or equipment.
20. Provide a \$5,000 allowance, included in base bid, to be used at the discretion of the Construction Manager.

CONTRACT NO. A-24 – TESTING & BALANCING

A. Work included in this contract consists of, but is not necessarily limited to, all labor, materials, and equipment for:

- Technical Specification sections:

Division 0	Bidding and Contract Requirements
Division 1	General Requirements
Section 220190	Testing – Plumbing
Section 220191	Balancing – Plumbing
Section 230900	Automatic Temperature Control
Section 230950	Testing & Balancing of Mechanical Systems

This contract also includes, but is not necessarily limited to, all labor, materials and equipment for the following:

1. Provide water and air testing and balancing.
2. Contractor shall prepare, at a minimum, a preliminary balance report for the Town of Middletown Final Inspection.
3. Provide pricing for all alternates as described in Section 012300-Alternates.
4. Submissions will be reviewed once and any resubmittals will be reviewed once. Any other submittals will be billed to the contractor at the Engineers standard rates. Please thoroughly review all submissions prior to forwarding to avoid these costs.
5. Provide complete signed and sealed testing report prior to substantial completion and final inspection as required by Town of Middletown L&I.
6. This contractor has been allotted 30 days to complete all work and provide final, sealed balancing report by the Construction Manager. This contractor will need to work closely with the Construction Manager and all MEP trades to sequence work so that the completion of the balancing is completed in a manner that does not delay acceptance from ~~NCC~~ **Town of Middletown** or ASD. **(BP1 ADDENDUM NO. 2)**
7. Provide confirmation of duct testing completed by Mechanical Contractor.
8. This contractor must provide all lifts or scaffold means to access all elements.
9. Provide at least a 48 hour notice prior to any delivery. All deliveries are to be between 7:00 AM and 3:30 PM.
10. This is not a secure site. All contractors are responsible for concealing, locking and/or removing any materials on a daily basis. ASD and EDiS will not be responsible for any lost tools, materials or equipment.

11. Provide circulating water system test. (BP1 ADDENDUM NO. 2)

CONTRACT NO. A-25 – TELEPHONE SYSTEM (BP1 ADDENDUM NO. 2)

A. Work included in this contract consists of, but is not necessarily limited to, all labor, materials, and equipment for:

- Technical Specification sections:

Division 0	Bidding and Contract Requirements
Division 1	General Requirements
Section 220190	Testing – Plumbing
Section 220191	Balancing – Plumbing
Section 230900	Automatic Temperature Control
Section 230950	Testing & Balancing of Mechanical Systems

This contract also includes, but is not necessarily limited to, all labor, materials and equipment for the following:

1. Provide media gateway, power supplies, battery back-up and other required equipment to extend the existing VoIP phone system.
2. Configure all extensions, mailboxes, DID's, entities, etc. as required. Coordinate all extension numbers and names with school district. Work with school district to ensure that the network infrastructure is properly configured to support VoIP system operation.
3. Provide and install administrative telephones. Patch cords from device to communication port (jack) provided by this Contractor. All network wiring between the MDF/IDF and the data jack shall be provided and terminated by the Structured Cabling contractor.
4. Provide and install and mount classroom telephones on the side of the Wardrobe cabinet as shown on drawings. Coordinate the locations with the Carpentry and General Works, Casework and Millwork contractor who shall provide hole for network cabling to pass thru. School district shall provide the patch cords from the device to the communication port (jack) to be installed and protected inside cabinet by this contractor. All network wiring between the MDF/IDF and the data jack shall be provided and terminated by the Structured Cabling contractor.
5. Configure the emergency notification system. Coordinate and provide output to the Special System contractor.
6. Provide as-built drawings.
7. Maintain equipment prior to substantial completion.
8. Provide specified warranties. All guarantees and warranties to begin at the substantial completion of the entire project.
9. Submissions will be reviewed once and any resubmittals will be reviewed once. Any

other submittals will be billed to the contractor at the Engineers standard rates. Please thoroughly review all submissions prior to forwarding to avoid these costs.

10. All costs for barricades, arrows, pedestrian protections, flag men, etc. will be part of this Contract. It shall be assumed there is at least 1 marked flagger to escort trucks through the project site.
11. Provide daily fine cleanup of the work is the responsibility of each individual Contractor which includes broom cleaning of their debris as required. Daily Fine clean up, on a daily basis, shall be defined as those means/methods utilized to perform the daily cleaning tasks without producing dust, noise and stacking of stored materials. Furnish fine clean up on a daily basis. All debris must be removed from the work area at the end of each work day to the appropriate dumpster.
12. Provide at least a 48 hour notice prior to any delivery. All deliveries are to be between 7:00 AM and 3:30 PM.
13. This is not a secure site. All contractors are responsible for concealing, locking and/or removing any materials on a daily basis. ASD and EDiS will not be responsible for any lost tools, materials or equipment.

END OF SECTION